

DOCUMENT RESUME

ED 417 073

SE 061 134

TITLE Upper School Maths: Lesson Plans and Activities for Ages 9-11 Years. Series of Caribbean Volunteer Publications, No. 9.

INSTITUTION Voluntary Services Overseas, Castries (St. Lucia).

PUB DATE 1997-00-00

NOTE 115p.; Some pages contain small or light type that may not reproduce well. Production funded by a grant from British Development Division, Caribbean.

AVAILABLE FROM VSO Resource Centre, 317 Putney Bridge Road, London SW 15 2PN, England, United Kingdom.

PUB TYPE Guides - Classroom - Teacher (052)

EDRS PRICE MF01/PC05 Plus Postage.

DESCRIPTORS *Arithmetic; Decimal Fractions; Educational Strategies; Elementary Secondary Education; Foreign Countries; Fractions; Geometry; Graphs; *Lesson Plans; *Manipulative Materials; *Mathematics Activities; *Mathematics Curriculum; Measurement; Percentage; *Problem Solving

IDENTIFIERS Caribbean

ABSTRACT

This collection of lesson plans and activities for students aged 9-11 years is based on a science curriculum developed by a group of Caribbean nations. The activities pertain to topics such as place value, prime and composite numbers, the sieve of Eratosthenes, square numbers, factors and multiples, sequences, averages, geometry, symmetry, tessellations, ominoes, measurement, capacity and mass, metric mass, time, money, fractions, decimals, percentage and ratio, graphs, and problem solving. The activities are organized by objectives from the core curriculum and frequently include worksheets for students. (DDR)

* Reproductions supplied by EDRS are the best that can be made *
* from the original document. *

ED 417 073



Upper School Maths: Lesson Plans and Activities for Ages 9 - 11 Years.

Series
of
Caribbean
Volunteer
Publications

PERMISSION TO REPRODUCE AND
DISSEMINATE THIS MATERIAL
HAS BEEN GRANTED BY

J. Nyisdale

TO THE EDUCATIONAL RESOURCE
INFORMATION CENTER (ERIC)

U.S. DEPARTMENT OF EDUCATION
Office of Educational Research and Improvement
EDUCATIONAL RESOURCES INFORMATION
CENTER (ERIC)

This document has been reproduced as
received from the person or organization
originating it.

Minor changes have been made to
improve reproduction quality.

Points of view or opinions stated in this
document do not necessarily represent
official OERI position or policy.

One of a series of publications produced by VSO
volunteers in the Caribbean. Production funded
by a grant from **British Development Division,**
Caribbean.

SE01134

9

Voluntary Services Overseas (VSO) is an independent British Charity which works to assist countries in the Caribbean, Africa, Asia and the Pacific to achieve their development aims and create a more equitable world. VSO volunteers work alongside people in poorer countries in order to share skills, build capabilities and promote international understanding and action.

Copyright VSO

Reproduction unlimited for public and educational uses - please acknowledge VSO series as source. No reproduction for commercial use without permission from VSO London.

Further copies are available, at cost of copying, from :

VSO Field Office
73, Chaussee Road
P.O. Box 1359
Castries
St. Lucia (Until December 1998)

VSO Resource Centre
317, Putney Bridge Road
London
SW 15 2PN
England (From 1999 onwards)

Upper School Maths

Lesson Plans and Activities.

Based on Junior 4 Curriculum

Curriculum Statements Included

ACKNOWLEDGEMENTS

VSO would like to extend their appreciation and gratitude to the following people who have made this series of publications possible:

- British Development Division (BDDC) for providing the funding for this series of publications
- Volunteers and local colleagues contributing to production of publications.
- Organisation of Caribbean Overseas Development (OCOD) for assisting in the reproduction of these publications

<u>CORE CURRICULUM OUTLINE</u>	6
<u>PLACE VALUE</u>	7
<u>EXPANDED FORM</u>	8
<u>PLACE VALUE</u>	9
<u>PRIME / COMPOSITE NUMBERS</u>	10
<u>SIEVE OF ERATOSTHENES</u>	11
<u>SQUARE NUMBERS</u>	12
<u>RECTANGLE NUMBERS</u>	13
<u>FACTORS - MULTIPLES</u>	14
<u>SQUARE NUMBERS</u>	15
<u>FACTORS - MULTIPLES</u>	16
<u>CORE CURRICULUM OUTLINE</u>	17
<u>EXCHANGE THE COUNTERS</u>	18
<u>SEQUENCES</u>	19
<u>JUMPS</u>	21
<u>FOUR RULES OF NUMBER</u>	24
<u>AVERAGES</u>	25
<u>AVERAGES SHEET 1</u>	26
<u>AVERAGES SHEET 2</u>	27
<u>JUNIOR 4 - MATHS TEST</u>	28
<u>CORE CURRICULUM OUTLINE</u>	29
<u>GEOMETRY</u>	30
<u>SYMMETRY</u>	34
<u>SYMMETRY</u>	36
<u>LINE SYMMETRY</u>	38
<u>TESSELLATIONS</u>	40
<u>TESSELLATION PATTERNS</u>	42
<u>OMINOES</u>	43
<u>LOWER SCHOOL MATHS HOMEWORK</u>	44

<u>MATHEMATICS EXAM JUNIOR 4 NOVEMBER 1994</u>	45
<u>MATHEMATICS EXAM JUNIOR 4 NOVEMBER 1994- ANS</u>	46
<u>CORE CURRICULUM OUTLINE</u>	48
<u>MEASURING</u>	50
<u>MEASUREMENT</u>	53
<u>OMINO PERIMETERS</u>	54
<u>CAPACITY AND MASS</u>	59
<u>CAPACITY</u>	61
<u>MASS</u>	62
<u>METRIC MASS</u>	63
<u>TIME</u>	64
<u>TIME - HOW DO YOU SPEND YOUR DAY?</u>	65
<u>CLOCKS</u>	66
<u>LOWER SCHOOL MATHS HOMEWORK -1</u>	66
<u>LOWER SCHOOL MATHS HOMEWORK -2</u>	69
<u>LOWER SCHOOL MATHS HOMEWORK -3</u>	70
<u>LOWER SCHOOL MATHS HOMEWORK -4</u>	71
<u>LOWER SCHOOL MATHS HOMEWORK -5</u>	73
<u>LOWER SCHOOL MATHS HOMEWORK -6</u>	75
<u>LOWER SCHOOL MATHS HOMEWORK -7</u>	77
<u>LOWER SCHOOL MATHS HOMEWORK -8</u>	79
<u>TIME LINES</u>	81
<u>MONEY</u>	82
<u>CORE CURRICULUM OUTLINE</u>	83
<u>SETS</u>	83
<u>SETS - VENN DIAGRAM</u>	85
<u>CORE CURRICULUM OUTLINE</u>	86
<u>FRACTIONS</u>	87
<u>FRACTIONS</u>	88

<u>FRACTION TREE WORKSHEET</u>	91
<u>FRACTION MAZE</u>	92
<u>CORE CURRICULUM OUTLINE</u>	93
<u>DECIMALS</u>	94
<u>CORE CURRICULUM OUTLINE</u>	95
<u>PERCENTAGE AND RATIO</u>	96
<u>RATIO</u>	97
<u>EXERCISES</u>	98
<u>CORE CURRICULUM OUTLINE</u>	99
<u>GRAPHS</u>	99
<u>CORE CURRICULUM OUTLINE</u>	101
<u>PROBLEM SOLVING</u>	102
<u>SUPPLEMENTARY OBJECTIVES</u>	104
<u>TRAVELING 11.3 AND 11.4</u>	106
<u>EXAMPLE - JUNIOR 4. MATHEMATICS EXAMINATION</u>	108

The activities in this booklet are based on the Junior 4 curriculum, St. Vincent and the Grenadines, but many of them can be used or modified by other primary school classes

It is hoped that the exercises in this booklet will enable teachers to introduce a variety of activities into their maths lessons. In compiling the booklet it was assumed that some basic skills have been taught and that teachers are looking for additional exercises to supplement their more formal teaching.

Curriculum statements, lesson plans, further ideas and activity sheets are included in the booklet. The activities have been used at the Rose Hall Government School, North Leeward, St. Vincent. Teachers involved in the trialling of these activities include: Mr R. Chambers, Ms G. Burke, Mr V. Crooke and Mr R. Stapleton. Jan Dingley (VSO) would like to thank the teachers for their co-operation and enthusiasm and also extend thanks to Mr Hugh Wyllie, Principal for his encouragement and support. Thanks also to Mr S. Jocelyn, Maths Teacher, Troumaca Ontario Secondary School for the typing, design, graphics and presentation of this booklet.

St. Vincent and the Grenadines
Mathematics

Core Curriculum Outline
10 - 11+ Year Olds

- 1.0 Number Concepts
- 1.1 Read and write numerals up to 9 999 999 using words and symbols
- 1.2 State the place value of a digit in a seven-digit numeral
- 1.3 State the value of any digit in a seven-digit numeral
- 1.4 Compare and order numbers up to 9 999 999
- 1.5 Identify prime numbers between 0 and 100
- 1.6 Distinguish between factors and multiples
- 1.7 Express numbers up to 144 as a product of prime factors
- 1.8 Find L.C.M. of given numbers (not more than 3) using sets of multiples
- 1.9 Identify square numbers up to 144 (12×12 or 12^2)
- 1.10 Round off numbers up to tens of thousands

BEST COPY AVAILABLE

Place Value

Core Curriculum: 1.0 Number Concepts (1.1, 1.2, 1.3, 1.4, 1.5, 1.6)

Age Range: 14

Group Size: 4-6

Objectives:

Before children can progress to carrying out operations on large numbers they need to understand the concept of place value. The digits 0-9 they know, they now need to learn the system of giving a symbol a different value by recognising the position it is in.

Resources:

Place Value Pack: digits 0 - 9 on small cards

Previous Knowledge:

It is assumed that students have some knowledge of place value - this activity gives further practice.

Task:

Each student has a 7 digit grid drawn in a book/on paper. Numbers are drawn at random from a pile of cards containing the digits 0 - 9. Students place the digits in the optimum position their grid so as to make the largest number. Points can be awarded each time the grid is complete (to the student making the largest number). Repeat the game 10 times or for 10 minutes.

Important Points:

- 1) This game encourages students to relate the position of a number with its place value.
- 2) Valuable group discussion occurs on place value.

Further Activity:

- 1) Each student should have a list of at least ten 7-digit numbers written down. Order these numbers (ascending and descending (1.4)).
- 2) Write each 7-digit number in words (1.1)

Expanded Form

One cup containing nine cards below is given to each group of four

1000 2000 3000 4000 5000 6000 7000 8000 9000

Also a second cup containing

100 200 300 400 500 600 700 800 900

A third cup containing

10 20 30 40 50 60 70 80 90

And finally a cup containing

1 2 3 4 5 6 7 8 9

Each child then takes a card from each of the four cups and arrange them in order of size, biggest first.

eg 5000 400 80 9 Each child then takes a turn to read their cards to the other children in the group e.g. 5489

At this point the teacher can demonstrate expanded notation and the children can associate this with the ordinary notation, e.g. $5489 = 5000 + 400 + 80 + 9$. The children can then practice this with some other numbers. Later on it can be suggested that the children take from just three cups to get numbers such as

$$6000 + 40 + 2 = 6042 \quad \text{or} \quad 9000 + 200 + 20 = 9220$$

Or take from just two cups

$$\text{eg } 7000 + 9 = 7009 \quad \text{or} \quad 200 + 30 = 230$$

Place Value

This activity provides a visual representation of the place value of digits. The teacher needs to prepare some visual aids.

Either

A large grid displaying the place value headings, (use Bristol board or other strong card) Attach "pockets" to each column to hold sticks, pencils, etc.

M	H.Th	T.Th	Th	H	T	O

Write these words in full

attach paper pockets which will hold sticks, pencils etc.

This chart represents 1,202,342

Move the sticks to show/represent different numbers and the place value of each digit.

OR:

Attach cardboard tubes (toilet rolls, kitchen rolls etc.) to a stiff piece of card. Mark each tube with the place value headings. Insert sticks, pencils etc. to represent different numbers.

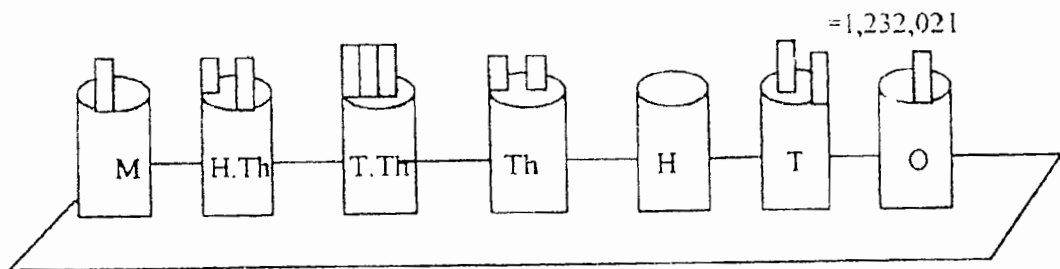

Groups of children could make these for themselves and set problems for each person in the group

33

Leave these visual aids on view in the classroom to reinforce the concepts which have been taught

Prime / Composite Numbers

Core Curriculum: 1.0 Number Concepts (1.7, 1.8,)

Age Range: J4

Group Size: Individual

Objectives:

To identify prime numbers 1 and 100 using the sieve of Eratosthenes. All remaining numbers (except 1) are composite.

Resources:

Each student needs a 10 x 10 number grid showing numbers from 1 to 100. (It is preferable if this is prepared before the lesson as it can be quite time consuming to draw - give as homework).

Previous Knowledge:

It is assumed that students have some knowledge of the terms factors and multiples.

Task:

It is important to stress that a prime number is a whole number with only two factors - itself and 1. (1 is not recognised as a prime number). A composite number is a whole number with more than 2 factors.

This exercise eliminates all numbers which have >2 factors.

1. Circle the number 2.
2. Cross out all multiples of 2.
3. Circle the number 3.
4. Cross out all multiples of 3.
5. Circle the next prime number on the list.
6. Cross out all multiples.
7. Repeat '5' and '6' above until all multiples have been crossed out.
8. The circled numbers are the prime numbers from 1 - 100.

Further Activity:

Further practice with factors, prime numbers, composite numbers from:
Caribbean Primary Mathematics Book 6

Page 1,	Lesson 2,	Exercise A, B, C.
Page 3,	Lesson 3 and 4,	Exercise C.
Page 9,	Lesson 19,	Exercise A, B, C.

Sieve of Eratosthenes

Prime Numbers from 1 - 100

1	②	③	4	⑤	6	⑦	8	9	10
⑪	12	⑬	14	15	16	⑰	18	⑱	20
21	22	⑳	24	25	26	27	28	㉑	30
⑳	32	33	34	35	36	㉗	38	39	40
㉙	42	㉓	44	45	46	㉕	48	49	50
51	52	㉖	54	55	56	57	58	㉘	60
㉚	62	63	64	65	66	㉜	68	69	70
㉞	72	㉟	74	75	76	77	78	㊱	80
81	82	㊲	84	85	86	87	88	㊳	90
91	92	93	94	95	96	㊴	98	99	100

Square Numbers

Core Curriculum: 1.9 Identify square numbers to 144

Age Range: J4

Group Size: Individual

Objectives:

Patterns of numbers occur frequently in mathematics, this activity encourages students to recognise some of these patterns, with special reference to square numbers.

Resources:

Paper and pencil

Previous Knowledge:

It is assumed that students are familiar with the process of factorising.

Task:

- Look at the factors of 12 i.e. 12×1 , 3×4 , 6×2 . Each pair can be represented in the form of a rectangle of dots:

12×1 6×2	4×3 etc.
--	-------------------------------------

- The next task is to look at the pattern formed when consecutive numbers are added, and then represented by dots, i.e.:

$1 = 1$.
$3 = 1 + 2$. .
$6 = 1 + 2 + 3$. . .
$10 = 1 + 2 + 3 + 4$
$15 = 1 + 2 + 3 + 4 + 5$
	etc.

- If we then add consecutive odd numbers a different pattern emerges, i.e.:

$1 = 1$	1^2	When the pattern of dots is drawn
$4 = 1 + 3$	2^2	it can be seen that these form
$9 = 1 + 3 + 5$	3^2	squares- corresponding to the
		square nos

continue to 144

Important Points:

Through drawing rectangles, triangles and squares students become more familiar with the concepts of pattern in number

Further Activity:

- 1 Students can investigate/extend these number patterns individually. This provides a differentiated exercise with students working at their own level
- 2 The topic leads naturally to the work on sequences (2.11)

Rectangle Numbers

The teacher presents the complete set of rectangle numbers for 12.



The teacher stresses that this is the complete set of possibilities. Six counters (e.g., bottle caps) are given to each group of four children. The teacher requests that each group finds the complete set of possible rectangle number pattern for 6.

When the teacher sees that this has been done by all groups she gives two more counters to each group and asks them to find the complete set of possible rectangle patterns for 8.

When all groups have finished, five more counters are given to each and the teacher requests that the complete sets be found for 9, 10, 11. Each group is given one piece of paper to record their results.

The teacher circulates to observe

As each group finishes the teacher can suggest that they explore the possibilities for the numbers 13 to 20. Any group that finished early could be advised to try numbers above 20.

Factors - Multiples

Multiples of 3

Fifteen counters are given to each group. . .

"Take three counters. Put three more next to them like this." . .

"How many counters do we have now?" . . .

"Put three more counters next to them like this." . . .

"How many counters do we have now?" . . .

etc. etc.

Continue

Counters are distributed a few at a time when needed.

When the children are confident with this procedure and have reached at least as far as 42 the teacher can say that these are multiples of 3.

Multiples of 4

The procedure is repeated for multiples of 4.

Factors

Each group has a record of the rectangle patterns for the numbers 1 to 20.

"Which of these numbers are multiples of 2?"

"Which of these numbers are multiples of 3?"

"Which of these numbers are multiples of 4?"

"Is there a number which is a multiple of 2, 3 and 4?"

The discussion may lead to the number 12.

"2, 3, 4 are said to be factors of 12."

"Are there any other factors of 12?"

"What are the factors of?" Try a few other numbers less than 20.

Factors

The teacher asks the class to recall the factors of 12. The rectangle patterns for 12 are drawn on the board.

..... "Here we have 1 row of 12" 1×12 is written on the board

..... "Here we have 2 rows of 6" 2×6 is written.

.....

This is done for the other rectangle patterns for 12.
When this is completed the teacher asks that all of the rectangle patterns for the numbers 1 to 20, on the groups sheet, be labelled in this way

"Teacher asks what are the factors of 12?"

1, 2, 3, 4, 6, 12

"So how many factors does 12 have?" (6)

"How many factors does 6 have?"

1, 2, 3, 6 (4)

"Look at your rectangle patterns for the numbers 1 to 20, which has the most factors?"
When each group has reached a conclusion the teacher says

"In your groups find out which number < than fifty has the biggest number of factors "

The teacher now withdraws as much as possible as the class work on this pattern.

Square Numbers

Teacher draws . . and . . .

 4 9

"What is special about these rectangles for 4 and 9?" (They are square number patterns)

"In your groups try and find other square number patterns."

The teacher will need to be patient as many incorrect arrangements will be made. The teacher should restrict her speech but occasionally emphasise that the patterns must be square.

FACTORS - MULTIPLES

- 1) Lists sets of factors logically - starting with 1 and the number 2 and 3, 3 and 4, etc.
e.g.

	24		36	
1	and 24	1	and 36	
2	and 12	2	and 18	
3	and 8	3	and 12	
4	and 6	4	and 9	
5	- no	5	- no	
6	-already paired.	6	and 6	
	(end)		(end)	

Ask children why there is no need to try other pairs.
Can they give a rule?

- 2) Give each pair (or group) one (or more) cards with a number in the middle. (Use multiples with more than one set of factors).

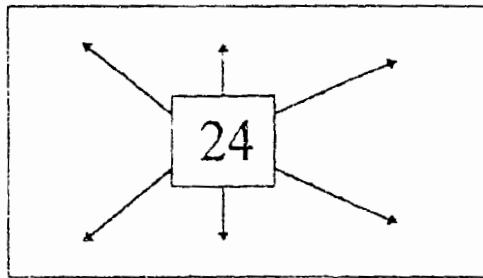

Ask children to mark the pairs of factors to produce cards like this one.

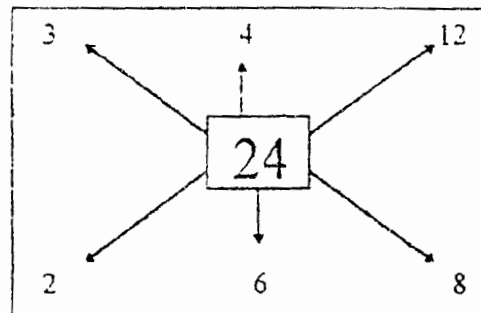

The finished cards could be displayed on the classroom wall.

- 3) Ask the pair (or group) to list as many statements as possible for the cards:-
- What is 2×12 ?
 - How many 3's in 24?
 - What is $24 \div 6$?
 - If one factor is 8, what is the other factor?





These questions should be displayed with the cards

St.Vincent and the Grenadines
Mathematics

Core Curriculum Outline
10 - 11+ Year Olds

- 2.0 Operations and relations
- 2.1 Build number sequences (no more than 10 numbers in a sequence) including fractional numbers.
- 2.2 Solve addition, subtraction, multiplication and division problems using whole numbers.
- 2.3 Estimate answers to problems by rounding off numbers to the nearest 10, 100, 10 000, 1 000 000.
- 2.4 Find averages using meaningful situations.

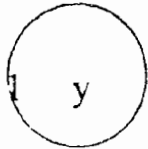
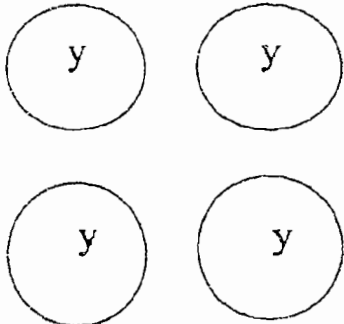
Exchange the counters

2		are worth 	1	
4		are worth 	1	

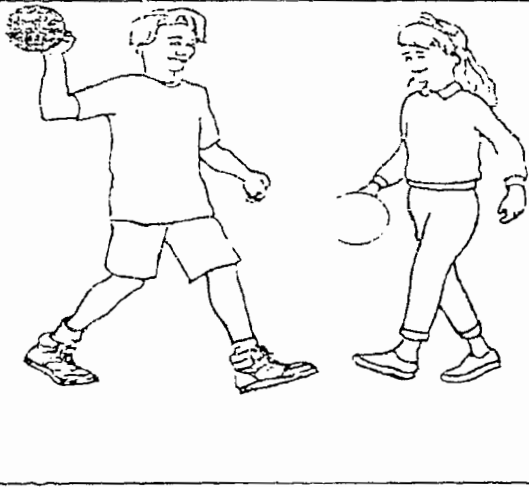
10 blue	→	<input style="width: 40px; height: 20px;" type="checkbox"/>	yellow		
8 yellow	→	<input style="width: 40px; height: 20px;" type="checkbox"/>	red		
20 yellow	→	<input style="width: 40px; height: 20px;" type="checkbox"/>	red		
8 blue	→	<input style="width: 40px; height: 20px;" type="checkbox"/>	red		
16 blue	→	<input style="width: 40px; height: 20px;" type="checkbox"/>	red		
7 blue	→	<input style="width: 40px; height: 20px;" type="checkbox"/>	yellow		
9 yellow	→	<input style="width: 40px; height: 20px;" type="checkbox"/>	red		
15 blue	→	<input style="width: 40px; height: 20px;" type="checkbox"/>	red		
		<input style="width: 40px; height: 20px;" type="checkbox"/>	blue		
		<input style="width: 40px; height: 20px;" type="checkbox"/>	yellow		
		<input style="width: 40px; height: 20px;" type="checkbox"/>	yellow	<input style="width: 40px; height: 20px;" type="checkbox"/>	blue

Sequences

Core Curriculum: 2.1 Build number sequences including fractional numbers.

Age Range: J4

Group Size: Individual / small groups

Objectives:

To continue the work from 1.9 of the core curriculum - to develop an understanding of the patterns which exist in number sequences.

Resources:

Paper and Pencil.

Previous Knowledge:

No specific pre-requisites - some previous work on number patterns may help some of the weaker students.

Task:

There are many examples of sequences which can be given to students. Here is a list of possibilities, some of which will extend the more able students.

1. Recognise basic pattern in number by completing the following:

2, 4, 6, 8, 10,	___	___	___	(counting in 2's)
3, 6, 9, 12, 15,	___	___	___	(counting in 3's)
3, 6, 12, 24	___	___	___	(doubling)
3, 7, 15, 31,	___	___	___	(doubling + 1)
3, 5, 9, 17,	___	___	___	(doubling - 1)
1, 3, 6, 10, 15	___	___	___	(triangular numbers)
1, 4, 9, 16, 25	___	___	___	(square numbers)

2. Recognising patterns in shapes: (use match sticks if available)

 | = | How many sticks?

 | = | = | How many now?

 | = | = | = | How many this time?

... extend this pattern and find the sequence
(Answer: 4, 7, 10, 13, ...)

3. Repeat 2 using triangles. Answer: 3, 5, 7, 9

4. Use examples involving fractions:
- | | | |
|----------------|-------|-----------------|
| 128, 64, 12, 6 | — — — | (halving) |
| 8, 4, 2, 1, | — — — | (halving) |
| 27, 9, 3, 0.3, | — — — | (division by 3) |

5. There are other sequences which students could investigate:

Pascal's Triangle

```

      1
     1 1
    1 2 1
   1 3 3 1
  1 4 6 4 1

```

etc.....

Fibonacci Series: 1, 1, 2, 3, 5, 8, 13, etc.

6. Some students may be able to cope with 3-D patterns, eg.
 15 balls are placed in a triangular frame. Another layer is placed on top so that the balls rest between the balls on the bottom layer. More layers are placed until only 1 ball is left at the top. (Shape = triangular prism)
 How many balls are in the pile?

Important Points:

These activities give scope for students to work at their own ability level - not all students would be able to handle the 3-D problem.

Further Activity:

Students should develop their own sequence which can be given to a partner to solve. This requires the student to think logically about the possible patterns / combinations of numbers which make a sequence.

NB: "Jumps" worksheets.

JUMPS

You need squared paper

Here is a different number pattern

0	3	6	9	12
5	8	11	14	17
10	13	16		
15	18			
20				32

As you jump across from each number to the next, you add 3.

We say the rule for jumping across is add 3.

0	→	3	→	6	→	9	→	12
5	→	8	→	11	→	14	→	17

As you jump from one number to the one below, you add 5.

The rule for jumping down is add 5.

0	↓	3	↓	6
5	↓	8	↓	11
10	↓	13		
15				

- Copy the pattern on squared paper. Write in the missing numbers.
- Can you find a rule for jumping from number to number like this? - must work for all the arrows.

Write down the rule.

- Is there a rule for jumping like this? What is the rule?

0	↘	3	↘	6	↘	9	↘	12
5	↘	8	↘	11	↘	14	↘	17
10	↘	13	↘	16				
15	↘	18						

0	↗	3	↗	6	↗	9	↗	12
5	↗	8	↗	11	↗	14	↗	17
10	↗	13	↗	16				
15	↗	18						

12 What is the rule for jumping one square up?

↑ 1	↑ 2	↑ 4	8
↑ 3	↑ 6	12	
↑ 9	18		
↑ 27	↑		

13 What is the rule for jumping two squares up?

1	↑ 2	↑ 4	8
↑ 3	6	12	
9	18		
27			

14 Here is a different number pattern
What is the rule for jumping?

(a) one square across

5	→ 15	→ 45
10	→ 30	→ 90
20	→ 60	→ 180

(b) one square down

↓ 5	↓ 15	↓ 45
↓ 10	↓ 30	↓ 90
↓ 20	↓ 60	↓ 180

(c) like this

5	15	45
10	30	90
20	60	180

- 4 These arrows jump two squares across.
Find a rule which works for all these
arrows.

0	3	6	9	12
5	8	11	14	17
10	13	16	19	22

- 5 These arrows jump two squares up
What is the rule for these arrows?

0	3	6	9	12
5	8	11	14	17
10	13	16	19	22
15	18	21	24	27

- 6 What is the rule for this kind
of jump?

0	3	6	9	12
5	8	11	14	17
10	13	16	19	22
15	18	21	24	27

- 7 What is the rule for this kind
of jump?

0	3	6	9	12
5	8	11	14	17
10	13	16	19	22
15	18	21	24	27

Here is another number pattern

1	2	4	8
3	6	12	
9	18		
27			216

The rule for jumping across is
multiply by 2.

1	→	2	→	4	→	8
3	→	6	→	12		

The rule for jumping
down is multiply by 3.

1	2
↓	↓
3	6
↓	↓
9	18

- 8 Copy the pattern. Write in the missing numbers.

- 9 Is there a rule for jumps like this?
Remember it must work for all the arrows.
Write down the rule.

1	2	4	8
3	6	12	
9	18		
27			

- 10 What is the rule for jumping two
squares across?

1	2	4	8
3	6	12	
9	18		
27			

- 11 What is the rule for jumping back
one square?

1	←	2	←	4	←	8
3	←	6	←	12		
9	←	18				
27						

Averages

Core Curriculum 2.4 Find averages using meaningful situations

Age Range: 14

Group Size: Individual and group activities

Objectives:

To introduce the concept of average and look at different situations where an average is used.

Resources:

Packets, boxes, etc. showing the word "average" e.g. toilet rolls, match boxes.
Averages Work Cards.

Previous Knowledge:

Children need to have some confidence at handling long multiplication and division.

Task:

1. Introduce the concept of average contents using practical materials e.g. Drawing pins - average contents 100 - ask questions such as 'Would you be surprised if a box had 99, 104, 150 pins?' 'What does average mean on a toilet roll wrapper?' 'How many sheets would you expect in a pack?' 'Could you be sure of getting this number of sheets?'
Give other examples as appropriate.
2. Give some examples for children to calculate - see attached sheet.
3. Introduce the average as a central value - use a group of children at the front of the class. Point out that one way to work out the average is to measure them all and calculate. Then show that by standing the group in order of height, the middle child would have the 'average' height.
4. Use the set of 'Averages Work Cards' which give further practical activities.

Important Points:

The work cards use differentiated examples to allow each child to progress at their own pace and to their own ability level.

Further Activity:

An additional sheet gives further work for the more able children. It involves calculating averages, finding values when the averages are given and discussion of the results.

BEST COPY AVAILABLE

Four rules of number

Core Curriculum 2.2 Solve $+$, $-$, \times , \div , problems

Age Range J4 NB The examples used here are relevant to all ages

Group Size: Individual / group depending on the activity

Objectives:

These are a series of number puzzles designed to give students plenty of experience in manipulating numbers using the 4-rules -the exercises will develop their ability to think logically

Resources:

Number grids, square paper, paper and pencil (depending on the activity).

Previous Knowledge:

Some formal experience of the 4 rules of arithmetic.

Task:

A separate booklet is available which provides examples of mathematical problems which further test a students' ability to handle addition, subtraction, multiplication and division.

Important Points:

Students may enjoy solving problems and puzzles. In these examples plenty of opportunity is provided for students to use their mathematical skills in a problem solving environment.

Further Activity:

The examples given can be extended, modified, simplified to suit the age and ability range of the students in a particular class

Averages Sheet 2

The table below shows some of the marks for a group of students in five exams:

	English	Maths	geography	Science	Art	Average
Brendan	58	43	75	53	62	
Oswald	80	40	56	59	73	
Natasha	40	50	53	44	63	
Alice	38	43		33	92	50
Janelle	72		69	38	49	63.6
Dexter	81	64	83		60	73.6
Marcus	56	59			71	61.2
Lisa	77	82	67	62		
Average			64.5			

- 1) Copy the table
- 2) Calculate the average marks for Brendan, Oswald and Natasha and write them in your table.
- 3)
 - (a) What was Alice's average mark?
 - (b) What was her total mark?
 - (c) What was her total mark for the four subjects given?
 - (d) What was her Geography mark?
- 4) What was Janelle's Maths mark?
- 5) What was Dexter's Science mark?
- 6) Find the average mark for the English exam and the maths exam.
- 7)
 - (a) What was the average mark for geography?
 - (b) What was the total number of marks for geography?
 - (c) What was Marcus' geography mark?
 - (d) Use your answer to (c) to help find his science mark
- 8) Find the average mark for science
- 9)
 - (a) What was the average mark for English?
 - (b) What was the average mark for art?

Averages Sheet 1

- 1 Last year, each of a farmer's six cows gave an average of 25 litres of milk a day
 - (a) About how much milk would he expect altogether from these cows each day?
 - (b) One day he gets 140 litres. Is that about average, above average or below average?

- 2 Different cars are different lengths. The average parking space a car needs is about 5 metres. Back Street is 176 metres long. About how much cars can park on one side of Back Street?

- 3 Matches are made from blocks of wood called cheeses. Each cheese makes about 22,000 matches. If a small match box contains 40 matches, how many small boxes can be made from one cheese?

St. Vincent and the Grenadines
Mathematics

Core Curriculum Outline

10 - 11+ Year Olds

- 3.0 Geometry
- 3.1 Identify and list properties (angles and sides) of the square, rectangle, triangle.
- 3.2 Identify right angles in plane figures including examples in the environment.
- 3.3 Distinguish between straight and curved lines
- 3.4 Distinguish between horizontal and vertical lines.
- 3.5 Identify and name the parts of a circle - radius, diameter, circumference, centre.
- 3.6 Calculate the radius of a circle given the diameter, or the diameter given the radius.
- 3.7 Investigate symmetry in the square, rectangle and circle by paper folding
- 3.8 Make patterns with geometric shapes that tessellate equilateral triangles, squares, rectangles, regular hexagons.

Junior 4 - Maths Test

- 1a. Write eight million, forty five thousand, one hundred and sixty five in digit form
- b. Write down the largest number that can be made with these digits

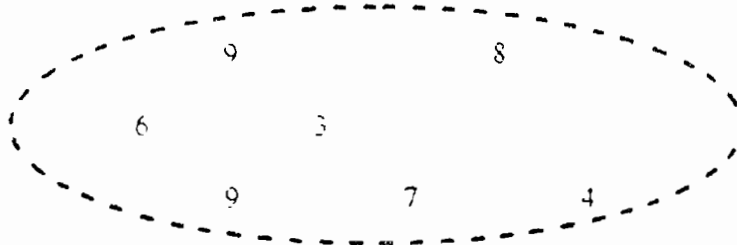

- c. Write the number you made in 1(b) in words.
- 2a. Write down the factors of 30.
- b. Which of the factors in 2(a) are prime numbers?
- 3a. Write down the next two numbers in this sequence.

$\frac{1}{4}$ $\frac{1}{2}$ 1, 2, 4, 8,

- b. Which of the numbers in 3(a) are square numbers?
4. Multiply 18 by 20 and divide the answer by 15.
- 5a. Find the average of these figures:
- 58, 89, 49, 38, 72, 81, 56, 77
- b. Which numbers in 5(a) are larger than the average?
- c. Which number in 5(a) is nearest to the average?

Important Points:

The use of maths trails , where children explore their environment looking for shapes, objects, etc. increases awareness of the child's surroundings and helps to develop an understanding of the concepts being studied

Further Activity:

Children could write up their maths trails for use by other groups in the same class or by other pupils in the school

Caribbean Primary Maths 6 p 36 lessons 60, 61

Geometry

Core Curriculum: 3.1, 3.2, 3.3, 3.4, 3.5, (Properties of shapes)

Age Range J4

Group Size Individual and group

Objectives

To introduce properties of the square, rectangle, triangle, circle, and distinguish between straight curved lines and horizontal, vertical lines.

To identify examples in the environment.

Resources:

Paper and pencil.

Previous Knowledge:

None required.

Task:

- 1) Define properties of:
 - (a) square - all sides equal, all angles right angles
 - (b) rectangle - opposite sides equal and parallel, all angles 90°
 - (c) triangles:
 - equilateral - all sides and angles equal.
 - right angle - one angle = 90°
 - isosceles - two sides equal
 - scalene - no sides or angles equal.
- 2) To define straight and curved lines
- 3) To define horizontal and vertical lines
- 4) Working in groups, children explore the school environment looking for examples of the above. (A mini - maths trail)
- 5) Draw and label the examples found in 4. (this can be done as a group activity or individual. The work could be completed in an art lesson.)

Now try these robot shape challenges!

1	do have	do not have	2	do have	do not have

Make one up of your own here:

1	do have	do not have	2	do have	do not have

Make up some more of your own.

BEST COPY AVAILABLE

Sort it out

These robots sort shapes in different ways
They have created a shape
challenge for you.

Look carefully at the
shapes below and
see if you can find
out how they sorted
these shapes.

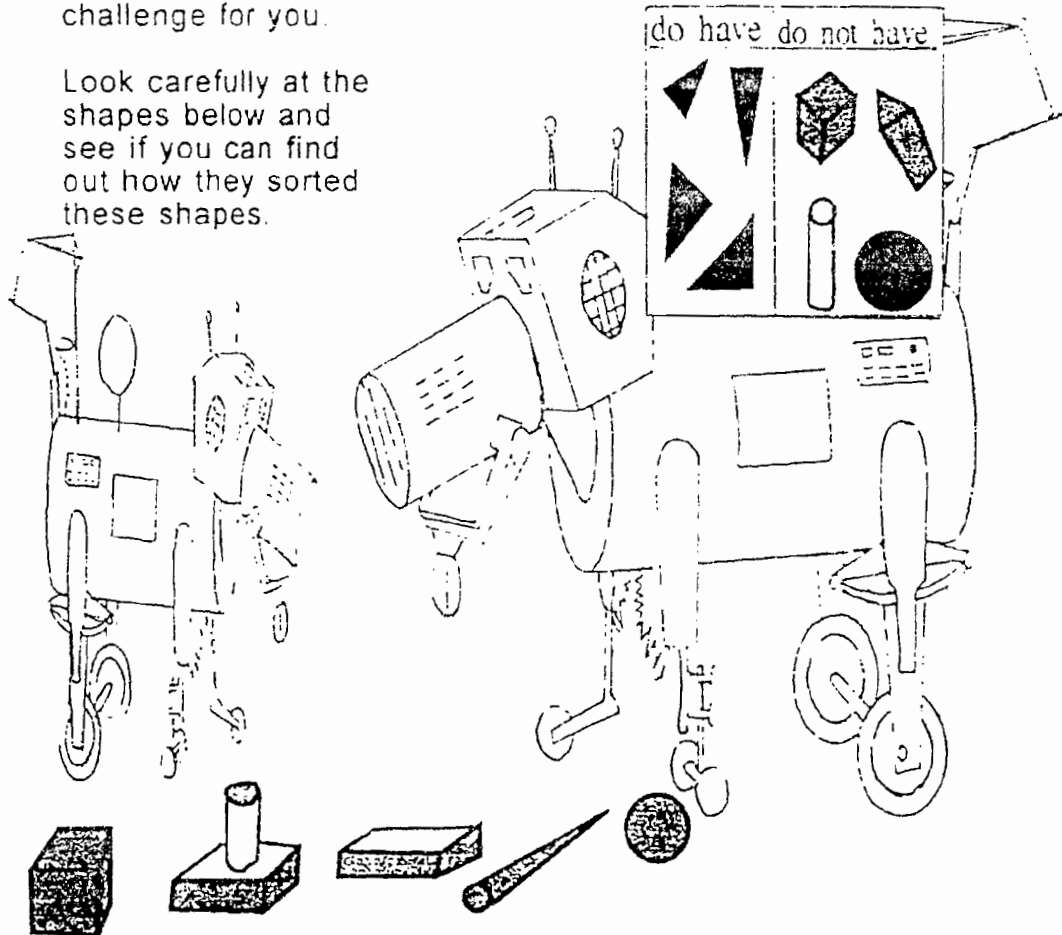

Turn the book upside - down to see if you got it right

They are sorted into shapes which have 3 sides
and shapes which do not have 3 sides
(OR: shapes which are triangles and shapes
which are not triangles.)

Symmetry

Core Curriculum: 3.7 Investigate symmetry by paper folding / cutting

Age Range: J4

Group Size: Individual

Objectives:

To introduce the idea of symmetry by paper folding and other exercises.

Resources:

Scraps of paper
Scissors
Symmetry worksheets (see attached)
Coloured crayons if available (not essential)

Previous Knowledge:

None required other than a basic understanding of the names and characteristics of shapes.

Task:

1. Each child is given scraps of paper which are folded once, twice, etc. Patterns/lines of symmetry in square, rectangle and circle are noted.
2. Scissors and paper are given to the children. The paper is folded once, a shape drawn then cut around the edge - when the paper is opened the pattern is symmetry.
3. Symmetry worksheet - gives further practice at recognising and completing patterns of symmetry with different shapes.
4. Symmetry grid worksheet - children need to make their own patterns - this could be done in pairs with one drawing the shape, the other drawing the mirror image.

Important Points:

This work increases a child's spatial awareness and increases dexterity through drawing. The colouring of symmetrical patterns could form part of an art lesson (a cross-curricular activity.)

Further Activity:

An extension of work on symmetry is to look at palindromic numbers e.g. dates and palindromic words. Children find this work interesting and it extends the work of symmetry to language work.

Geoboards and multi-block boards give further experience in developing and recognising symmetrical shapes.

Caribbean Primary Maths 6. p.87,88,89, lessons 136 - 139

Face Masks are usually symmetrical = art lesson?

Kite ----- group activity / art.

Please ask your mom or dad for help, or anyone who's around - if you need it.

MATHS HOMEWORK

Name _____ Group _____ Date _____ Hand in by _____

Complete these symmetrical patterns.

They should look the same on either side of the broken line.

You might like to colour the patterns you have made.

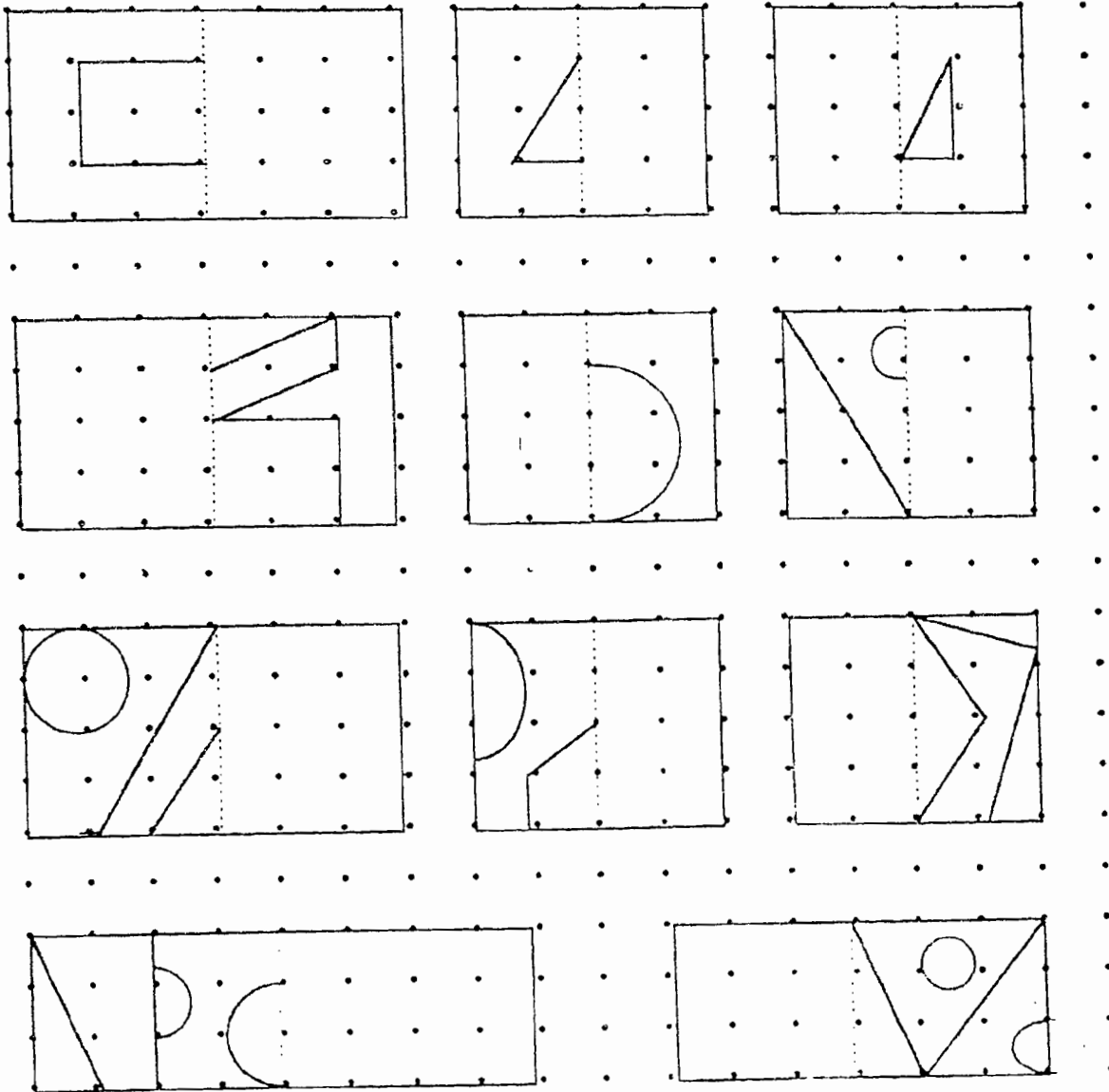

An earthworm can pull ten times its own weight.

Symmetry

Colour in the other half of this grid to make a symmetrical pattern.

The line down the middle of the grid is called a **line of symmetry**.

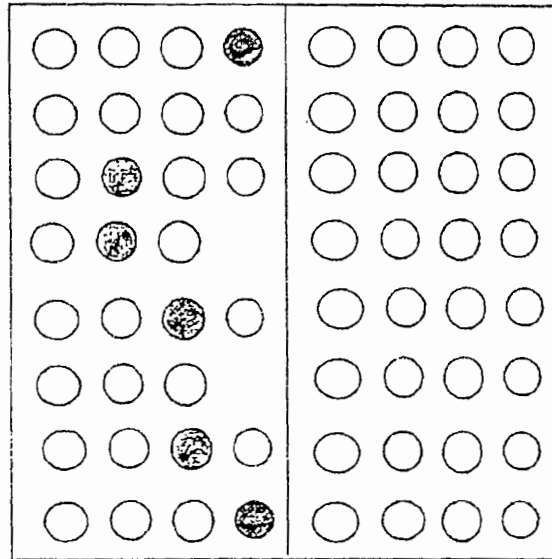
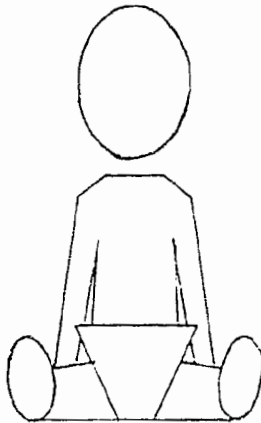

Now colour in this grid where the line of symmetry is a different place.

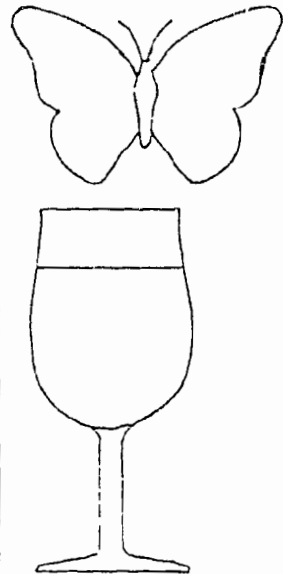
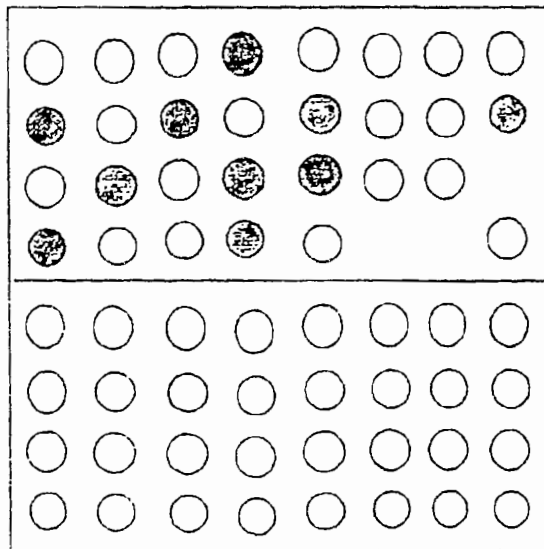
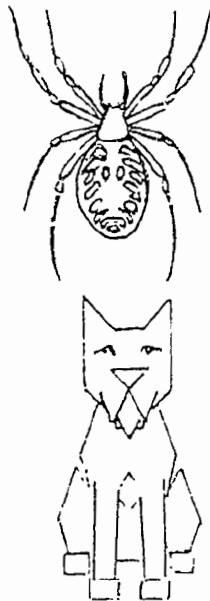

This pattern has two lines of symmetry.

Look carefully at how the pattern is symmetrical in two ways.

Now colour in these patterns with two lines of symmetry

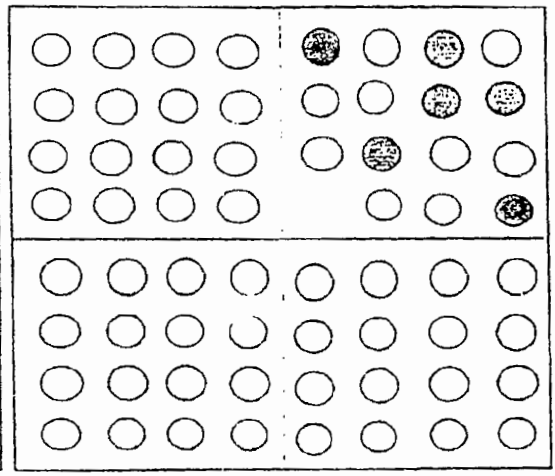
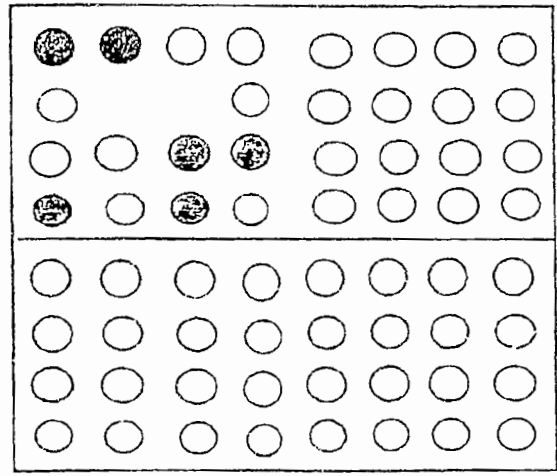
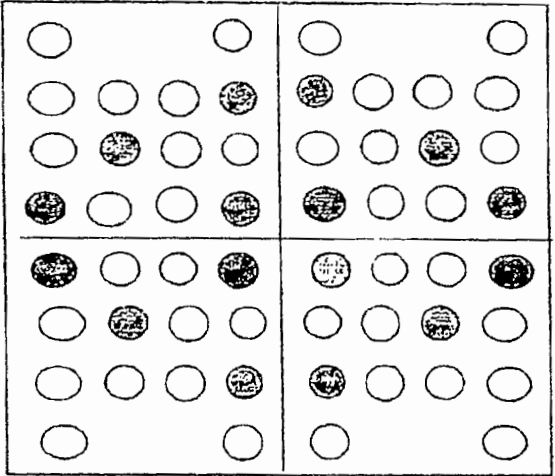

You might find it easier if you turn the book around as you go!

Use this grid to make a symmetrical pattern of your own. Draw in your pattern's line of symmetry

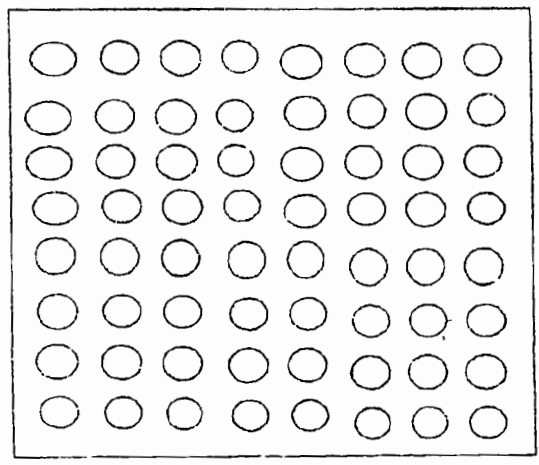
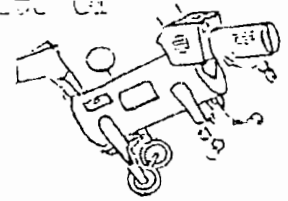

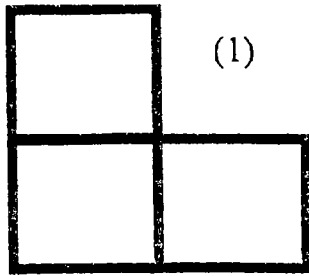

Add a single square to these shapes to make them symmetrical.

Some have more than one possibility - try to find them all.

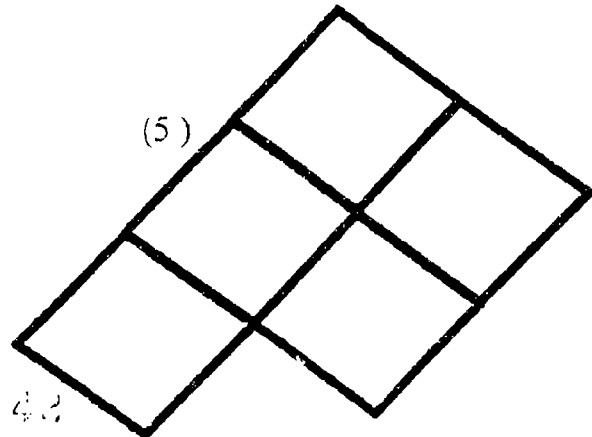
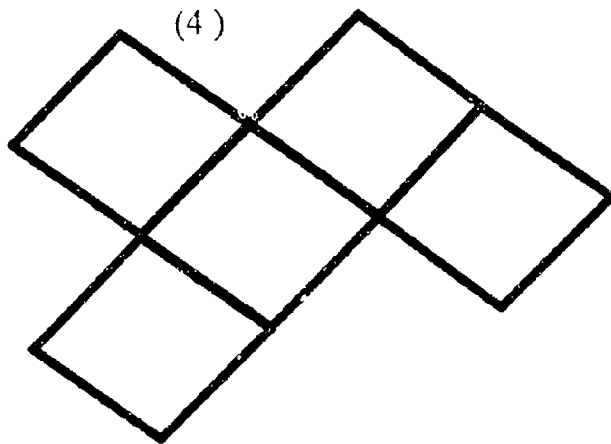
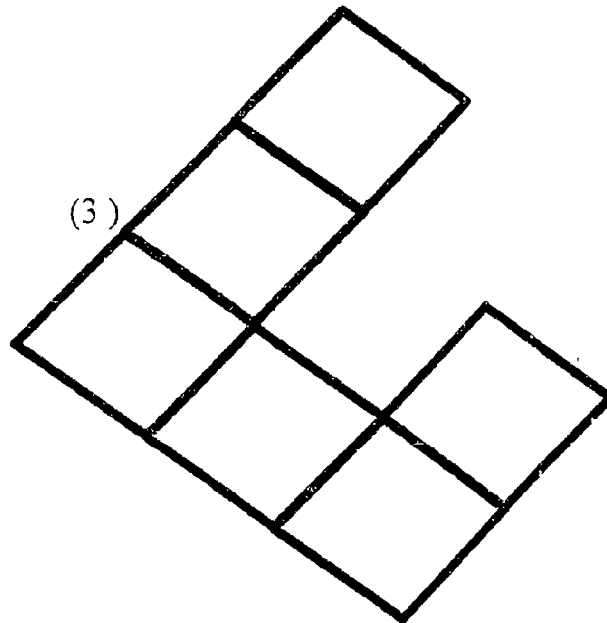
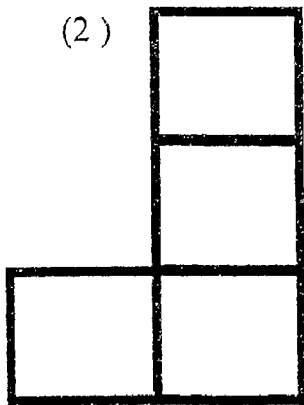

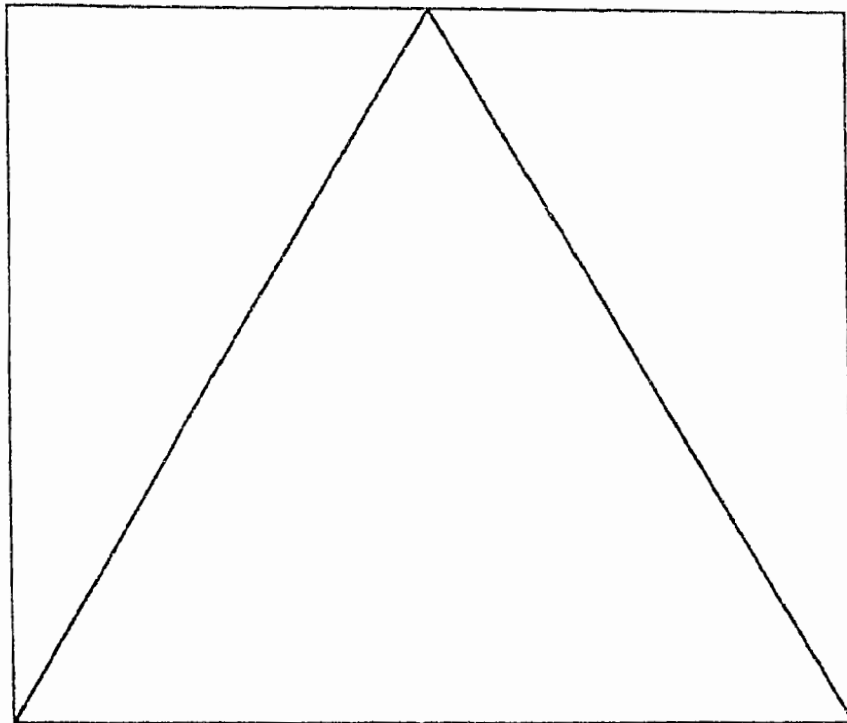

Cut along the lines of the drawing above.

Using all three pieces you can construct each of the five shapes below.

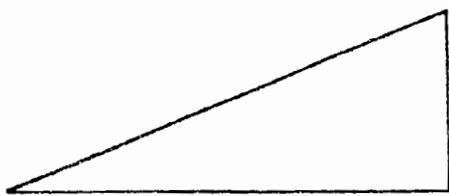

Right-angled triangle

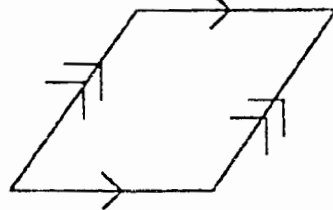

Parallelogram

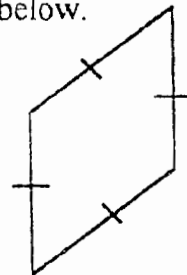

Rhombus

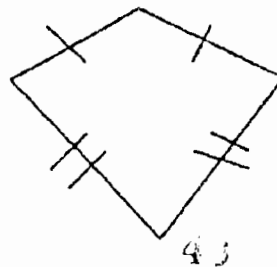
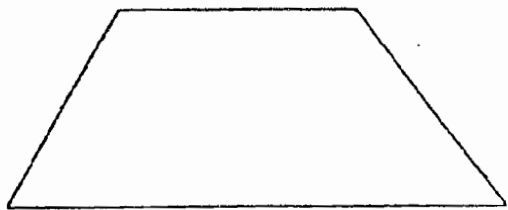

Tessellations

Core Curriculum: 3.8 Make patterns that tessellate.

Age Range: J4

Group Size: Individual and group activity.

Objectives:

To develop an appreciation of a tessellation as a repeating pattern using a square, rectangle, equilateral triangle and a regular hexagon.

To extend the basic idea of a regular repeating pattern by using half turns, whole turns, etc. to develop more complicated tessellations.

Resources:

Paper and pencil.

Coloured crayons improve the overall presentation.

Collection of shapes cut from stiff cardboard.

Spotty paper if available (this can be produced on a spirit duplicator or Gestetner stencil).

Previous Knowledge:

Children should be able to identify the shapes mentioned above.

Task:

- 1) Look at regular patterns produced by tessellating a square, triangle and rectangle.
- 2) Develop patterns using shapes displayed by half, quarter, etc.
- 3) Extend the patterns using half and whole turns.
- 4) Draw patterns on spotty, square paper, etc. and colour.
- 5) Look at tessellations involving large and small squares, etc.
- 6) Look at tessellations involving two shapes.
- 7) Extend to more complicated and irregular shapes and note the results.
- 8) Use isometric paper to develop and record patterns.

Important Points:

This work develops the idea of pattern and continuity and extends the work on symmetry by investigating regular patterns. Some children will find anything other than the basic work extremely difficult until sufficient practice has been given. (Isometric paper may be useful for those children who cannot easily recognise pattern).

Further Activity:

This work can be extended by using >2 shapes of different sizes/shape to produce complicated patterns.

Encourage the use of turns to extend patterns.

Introduce the idea of least common shapes (see attached sheets).

Tessellation Patterns

Each group of 4 children needs a ruler, a pair of scissors and some cards. Four 5cm squares are given to each group.

Teacher says:

“Take a square”



“Cut along a diagonal”



The following tiles can be made by putting the two pieces together in different ways.

The teacher demonstrates

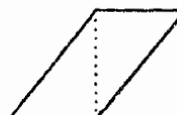
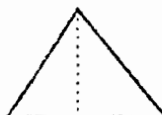
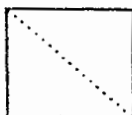

Each group is asked to make these tiles out of their pieces. These shapes are drawn around to make cardboard templates. The teacher demonstrates how squares can be put together to cover a surface without gaps.

i.e.

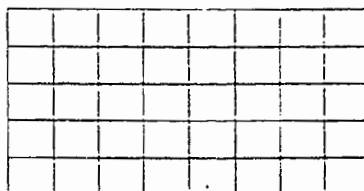

The children are then asked to show how this can be done with the other two shapes. They can use their templates to draw the tiling patterns. These patterns can be drawn onto a sheet of paper shared by the group.

Take three “half-squares”



Which shape tiles can be made by putting them together?

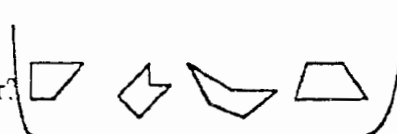

These shapes can be made into cardboard templates. The children are asked to show how the shapes can be arranged into tiling patterns. (There is more than one way for most of the shapes.)

In describing the patterns both the teacher and children will be using words such as “square”, “triangle”, “straight”, “right angled”, “horizontal”, “vertical”, “parallel”.

Ominoes

5cm squares are given to each group of four children.

Teacher demonstrates: There is one domino (2 squares)

The are two trominoes (3 squares)

The children are asked to use their squares to show which tetrominoes (4 squares) can be made.

(Patterns like these are not allowed

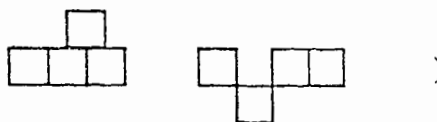

As they are made one person in each group should draw the tetrominoes that have been made so as to keep a record. As the groups find the complete set (there are five) an additional square should be given to each group and they can be asked to try and find the set of (12) pentominoes (5 squares). It is very hard to find all of them.

Tessellating - Ominoes

Dominoes can tessellate like this

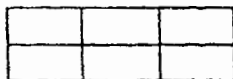

Can trominoes be tessellated? The children are asked to show how.

Cardboard trominoes are distributed - one type to each group. The children are asked to show how they can be tessellated. The groups can exchange with each other to try other tetrominoes.

Hex-Ominoes and Cube Nets

Here is a Hexomino

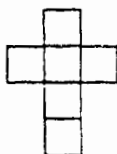

It can be folded to make a cube.

Each group is given six squares and some scotch tape. Which other hexominoes are also cube nets? There are about twelve but some are hard to find.

If you need help ask anyone who's around.

LOWER SCHOOL MATHS HOMEWORK

Name _____ Group _____ Date _____ Hand in by _____

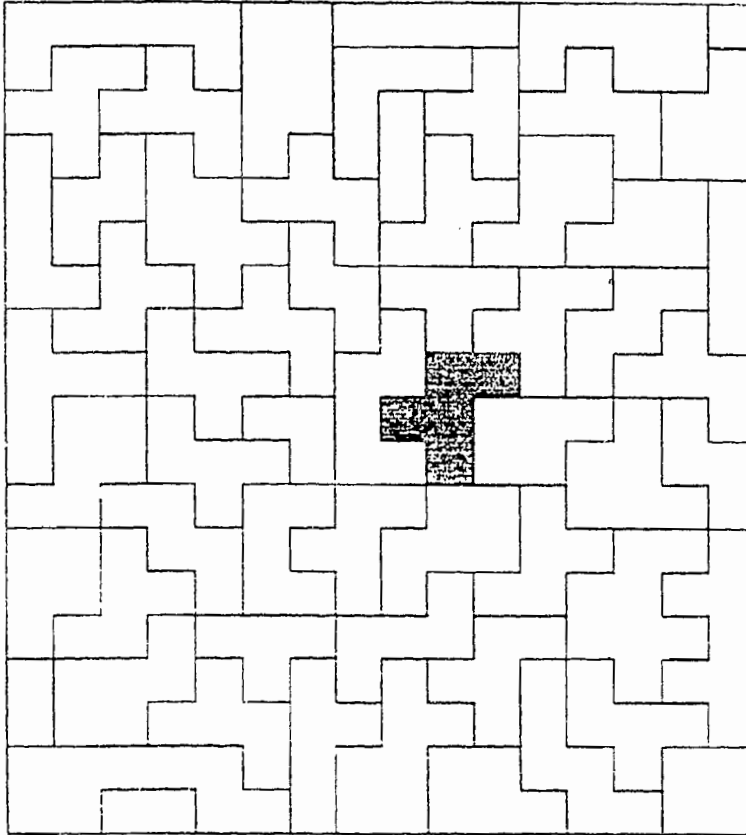

There are 18 shapes like this

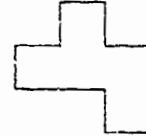

in the pattern.

Shade each one as you find it.

One has been done to give you a start.

The shape you have shaded is made from five squares like this

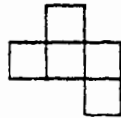

All the other shapes are made up from squares too.

Write the number of squares you think each shape is made from inside them.

Hint: The square in the top right hand corner is the size of square the shapes are made from.

Mathematics Exam Junior 4 November 1994

Answer all the questions.
Show all your working out.

1. (a) Write eight million, seven hundred and sixty three thousand, four hundred and ninety six in numbers.
- (b) Write 5, 496,072 in words
- (c) State the value of the underlined digits in the following:
1,397,621 2,483,542 1,076,304
- (d) Write the numbers in part (c) in descending order.
- (e) Round 1,397,621 to the nearest thousand
Round 2,483,542 to the nearest hundred
Round 1,076,304 to the nearest million.
- 2) Write all the prime numbers between 10 and 30.
- 3) (a) Write the factors of 18
- (b) Write the factors of 27
- (c) Write the factors of 36
- (d) Write the factors of 45
- (e) Write the set of multiples of 3 between 20 and 40
- (f) Write the set of multiples of 5 between 19 and 49
- (g) Write the set of multiples of 11 between 50 and 100
- (h) Find the LCM of 3, 5, 15
- (i) Find the LCM of 3, 9, 12

43

(j) Find the LCM of 10, 15, 20

4) Write the next 3 numbers in the following sequences:

(a) 3, 6, 9, 12

(b) 1, 10, 100, 1000

(c) 81, 72, 63, 54

(d) 4, 9, 16, 25

Mathematics Exam Junior 4 November 1994- Ans

Answer all the questions.

Show all your working out.

1. (a) Write eight million, seven hundred and sixty three thousand, four hundred and ninety six in numbers. 8,763,496

(b) Write 5,496,072 in words- five million four hundred and ninety six thousand and seventy two.

(c) State the value of the underlined digits in the following:

1,397,621^{7 thousand} 2,483,542^{400 thousand} 1,076,304³⁰⁰

(d) Write the numbers in part (c) in descending order.

2,483,542 1,397,621 1,076,304

(e) Round 1,397,621 to the nearest thousand 1,398,000

Round 2,483,542 to the nearest hundred 2,483,500

Round 1,076,304 to the nearest million. 1 million

2) Write all the prime numbers between 10 and 30.

11, 13, 17, 19, 23, 29

3) (a) Write the factors of 18 - 1, 18, 2, 9, 6, 3

- (b) Write the factors of 27 - 1, 27, 3, 9
- (c) Write the factors of 36 - 1, 36, 4, 9, 6, 6, 2, 18, 3, 12
- (d) Write the factors of 45 - 1, 45, 9, 5, 15, 3
- (e) Write the set of multiples of 3 between 20 and 40
21, 24, 27, 30, 33, 36, 39
- (f) Write the set of multiples of 5 between 19 and 49
20, 25, 30, 35, 40, 45
- (g) Write the set of multiples of 11 between 50 and 100
55, 66, 77, 88, 99
- (h) Find the LCM of 3, 5, 15 - 15
- (i) Find the LCM of 3, 9, 12 - 36
- (j) Find the LCM of 10, 15, 20 - 60
- 4) Write the next 3 numbers in the following sequences:
- (a) 3, 6, 9, 12, 15, 18, 21 (b) 1, 10, 100, 1000, 10000, 100000, 1000000
- (c) 81, 72, 63, 54, 45, 36, 27 (d) 4, 9, 16, 25, 36, 49, 64

St. Vincent and the Grenadines

Mathematics

Core Curriculum Outline

10 - 11+ Year Olds

4.0 Measurement

4.1 Length

4.1.1 Estimate and measure lengths using mm, cm, m.

4.1.2 Find the perimeter of regular and irregular shapes.

4.1.3 Find distance in km.

4.1.4 Measure lengths in one unit and record using a larger unit.

4.1.5 Solve problems involving mm, cm, m, km.

4.2 Area

4.2.1 Find the area of regular and irregular shapes.

4.2.2 Find surface area of objects by measurement and calculation.

4.2.3 Calculate the length of a rectangle given the area and the width, or calculate the width given the area and the length.

4.3 Capacity

4.3.1 Estimate and measure the capacity of containers in ml or litres.

4.3.2 Compare the capacity of containers.

4.3.3 Solve problems involving ml or litres.

4.4 Mass

4.4.1 Estimate and measure the mass in gms or kg of various objects

4.4.2 Compare the mass of different objects.

4.4.3 Solve problems involving mass.

4.5 Time

- 4.5.1 Tell the time in hours and minutes.
- 4.5.2 Tell the time in hours and minutes that elapsed between given times.
- 4.5.3 Change a number of minutes to hours and minutes.
- 4.5.4 Find the time in different time zones.
- 4.5.5 Interpret information from a calendar.

4.6 Money

- 4.6.1 Calculate bills and make change from amounts up to \$100.
- 4.6.2 Find the total price paid for an item given the down payment and the instalments.
- 4.6.3 Find the profit or loss given the cost and selling prices.
- 4.6.4 Convert foreign currency to local currency using current exchange rates.

Measuring

Core Curriculum: 4.1, 4.2 (Measurement: length and area)

Age Range: J4

Group Size: Individual/ Group

Objectives

To develop the concept of perimeter, area and distance using mm, cm, m, km, through estimation and measuring.

Resources:

Rulers, string for measuring.
Square paper for drawing accurately.

Previous Knowledge:

Some previous knowledge of these topics is assumed.

Task:

1. Estimate lengths of different objects by using 10cm and 50cm strips of paper. Children estimate shorter and longer objects and then measure accurately. Results can be recorded in a table

Object	Estimated Length	Actual Length	Error (smaller/larger)	Measured Error
--------	------------------	---------------	------------------------	----------------

2. Show a large ruler, mark different points e.g. 12cm, 27cm, 43cm, etc. Calculate distances between the end points of the ruler and the given points and between the points themselves. Give answers in mm and cm.
3. Calculate the perimeter of regular shapes e.g. square, rectangle, triangle.
4. Calculate the perimeter of irregular shapes e.g. a leaf, a 'blob', etc. using a piece of string to measure around the edge and then a ruler to measure accurately.
(C.P. Maths, Bk6, pp.5, 39, 40, 63)
5. Area of regular shapes by calculation. Show that the area of a triangle is half the area of a rectangle to introduce the formula $\text{area} = \text{length} \times \text{height} \div 2$.
6. Area of irregular shapes by drawing on square paper and counting the squares, (part squares $>$ half are also counted.) e.g. letters such as 'S'. (C.P. Maths, Bk2, pp.5, 40, 65)

BEST COPY AVAILABLE

5.

Important Points:









Pupils can investigate many aspects of measuring before the theory is introduced - these lessons should be as practical as possible.

Further Activity:

1. The exercise in C.P. Maths can be used during the lessons or as revision later.
2. Further activity in drawing and measuring can be part of the art lesson, e.g. draw around a hand and measure the perimeter/area, draw the letters of a pupil's name and measure the perimeter (complicated!) and area. All work can be mounted on the wall.

 <p>1cm</p>	<p>When you measure you often use centimetres. We write this as cm. There are 100cm in 1 meter</p>
--	--

Measure in cm. Use your ruler.

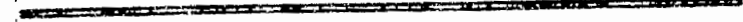
	...7... cm
 cm
 cm
 cm
 cm
 cm
 cm
 cm
 cm
 cm

Make a drawing of a friend or of yourself.
 Measure various lengths and write them
 on your drawing.

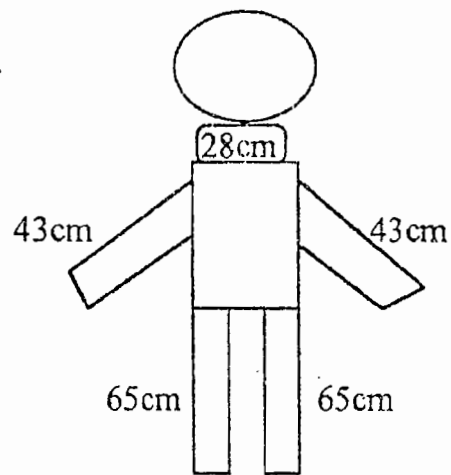

Write a list of names beginning with the shortest
 and finishing with the tallest.

Val	122cm	Steven	109cm	Joe	127cm
Ann	131cm	Pat	141cm	Sue	142cm
Peter	123cm	John	114cm	Ian	128cm

How tall are you?

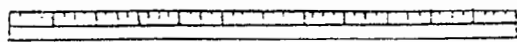

.....

.....

.....

.....

.....

.....

.....

Find some things to measure

Object	I guess its length to be	I measure its length to be	Difference
Book			
Piece of string or ribbon			
Window sill			
Desk top			
Black-board			

Find other things to estimate and measure.

Measurement

Length

Give a selection of about ten objects to each group of four children (e.g. textbook, pencil, belt, cane, board eraser, a roll of paper, eraser, stick, spray can, bottle.)

Each group is asked to arrange their objects in order of length. One child can be asked to write down a list of the objects in this order.

A strip of unmarked paper is given to each group - the teacher saying how long it is.

The children are asked to estimate the length of each of the objects by comparing them with each other and with the strip of paper. The estimates are written on the list.

As each group finishes a 30 cm ruler is given so that the exact lengths can be measured and recorded next to the estimated lengths.

This lesson should be repeated once or twice but with different objects (the group could exchange) and with different length strips of paper. This will help the children to develop more precise methods in estimating lengths and also give practise in making accurate measurements. Estimation in metres should take place in later lessons.

Omino Perimeters

Six 5cm squares are distributed to each group of four children. The teacher draws a Hexomino pattern on the board

e.g.

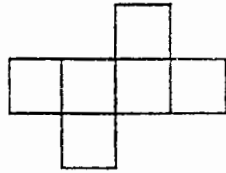

The teacher shows how to count the distance around the outside. In this case the distance is 14. The teacher draws another Hexomino pattern.

e.g.

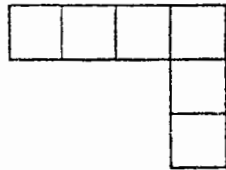

The children are asked to make the shape with their squares and count the distance around. (Again the answer is 14)

The children are asked to make other Hexominoes and count the distance around. Is the distance always 14? A sheet of paper is given to each group so that the results can be recorded.

(Patterns like these are not allowed

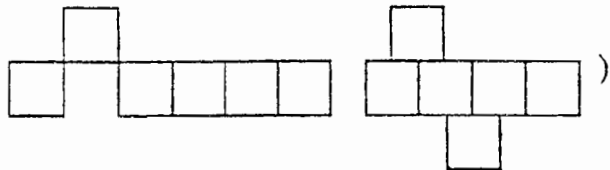

As the children start reaching conclusions it could be suggested that they attempt the investigation with pentominoes (5 squares), Tetrominoes (4), and Trominoes (3). They should be encouraged to tabulate their results clearly.

Both this and the next lesson give practise in measuring around irregular shapes.

First guess the perimeter of each shape. Then measure with your ruler. Work out how wrong you were.

Guess	Measured	Difference
A.....cmcmcm
B.....cmcmcm
C.....cmcmcm
D.....cmcmcm
E.....cmcmcm
F.....cmcmcm

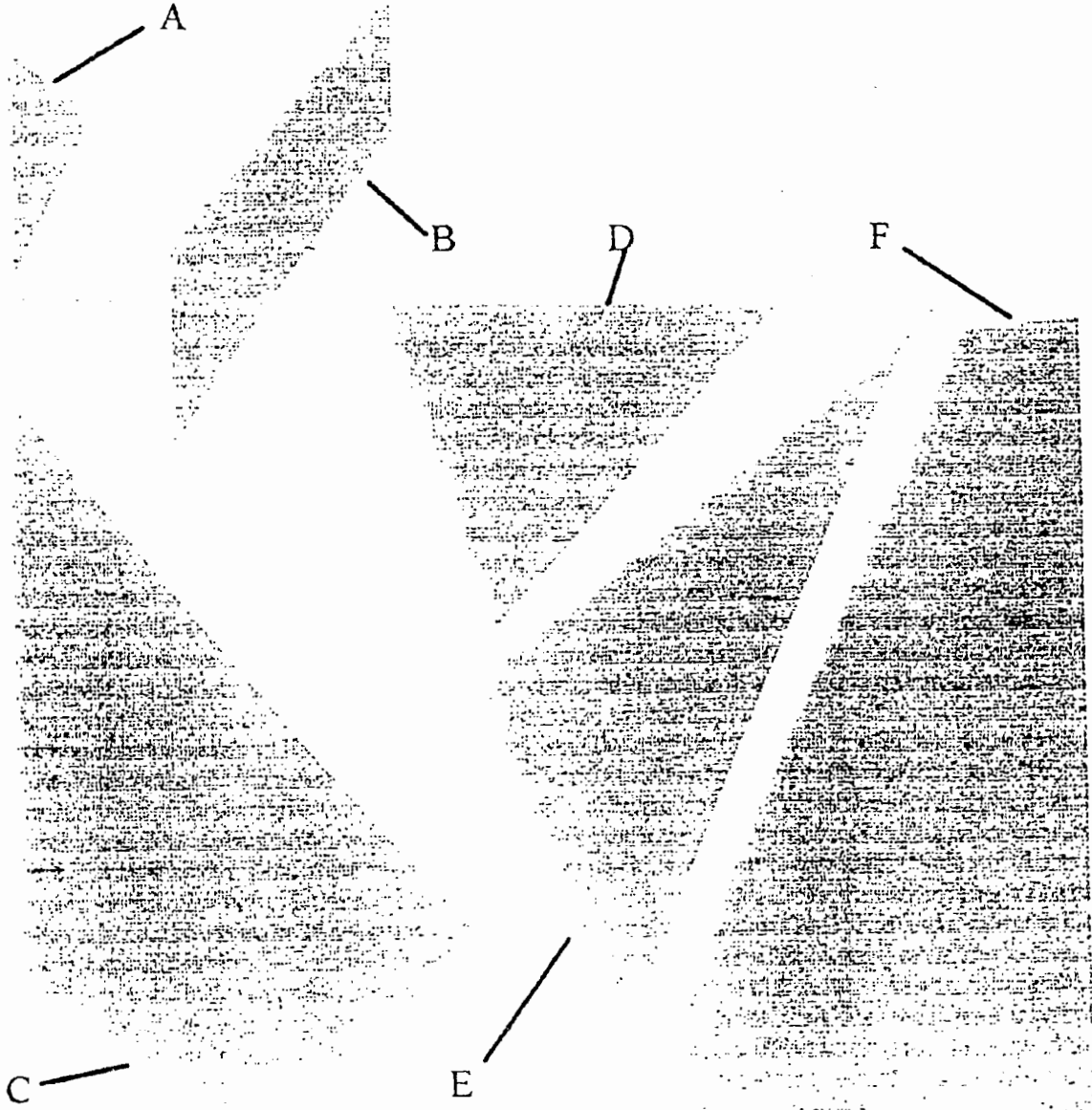

Measure each side and write down how long it is.
Also work out the perimeter.

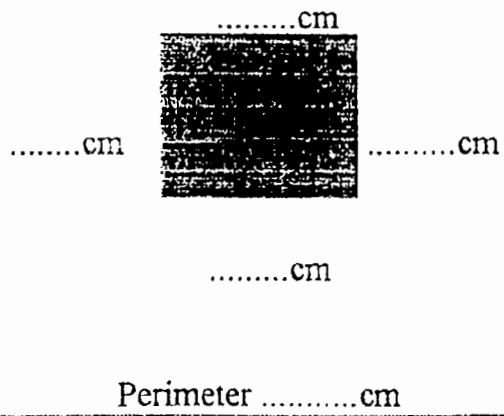
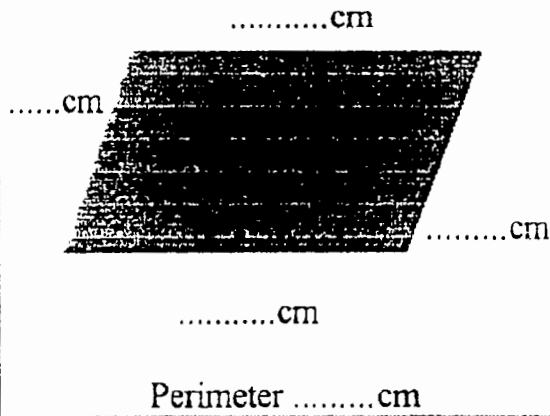
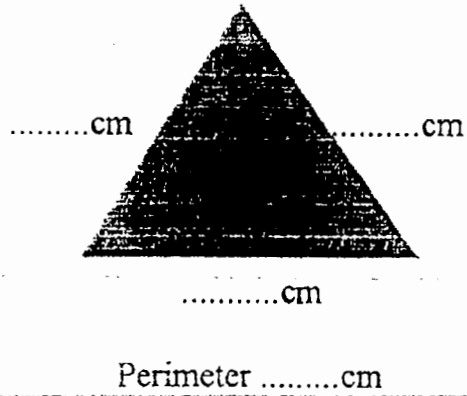
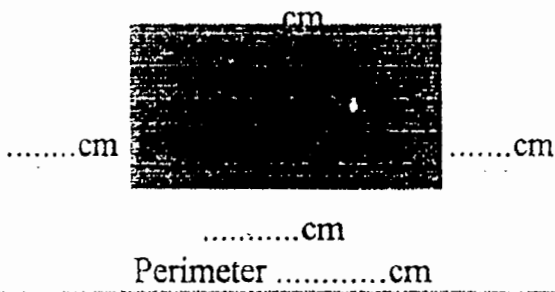



Can you name the shapes?

If you need help with the homework, please ask anyone who's around.

LOWER SCHOOL MATHS HOMEWORK

NAME _____ GROUP _____ DATE _____ HAND IN BY _____



THE AREA OF THIS SQUARE  IS 1

THE AREA OF THIS TRIANGLE  IS 1/2 A SQUARE

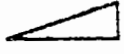

THE AREA OF THIS TRIANGLE IS 1 SQUARE  (IT IS EXACTLY HALF THE AREA OF 2 SQUARES)

Complete this table

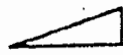
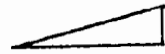
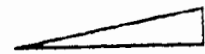
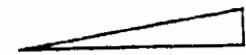
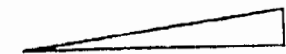
Triangle	Description	Area
	The triangle is 1/2 of 1 square	1/2 a square
	The triangle is 1/2 of 2 squares	1 square
		
		
		
		
		



Work out the area of each pattern.

Write the total area next to the pattern.

Draw some of your own patterns in the space at the bottom of the page.

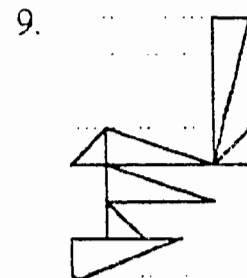
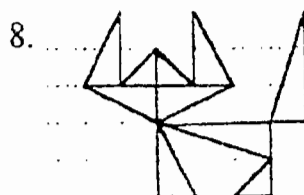
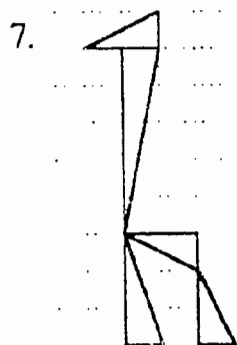
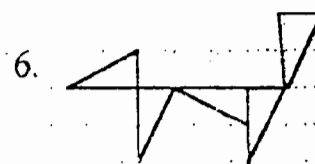
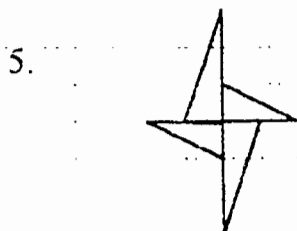
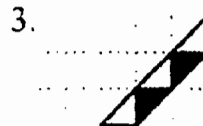
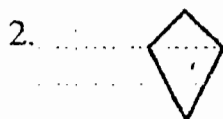
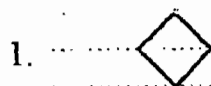

Capacity and Mass

Core Curriculum: 4.3, 4.4 (Capacity and Mass)

Age Range: J4

Group Size: Individual and group.

Objectives:

To develop the concept of estimating and measuring accurately with reference to capacity and mass.

Resources:

A range of different size containers and objects of different weight are required to provide hands on experience.

Scales and measuring jugs for accurate measurement.

Previous Knowledge:

Some familiarity with ml, litre, gm, kg, etc. is assumed.

Children will already have had experience of estimation from their work on measuring.

Task:

1. As for measuring, give a range of objects and estimate their capacity/weight.
2. Measure accurately and draw up a table to show results. It is a useful exercise to record the error in terms of 'larger' or 'smaller' and in actual measurements.
3. Some formal exercise in conversion of measurements can be included - C.P.Maths Book 6, pp.59, 60.

Important Points:

If little equipment is available it may be necessary to split the class into groups, one working on capacity, one on mass.

Further Activity:

An interesting and stimulating way to complete this work on measurement is to use a series of cards marked with equivalent lengths, weights and measurements i.e. 100cm, 1m, etc. Children play a game of cards collecting equivalent cards. The winner is the one with the largest number of pairs. This stimulates much discussion and checking of pairs. (see examples below)

Decimal equivalents could be included (0.5m, 50cm, etc.) if the children are competent at handling decimals.

NB. If the syllabus is followed in numeric order decimals are not covered until part 7, so some alteration to teaching order would be required.

Equivalent cards

Prepare cards similar to these

0.1m	0.2m	0.3m	etc.
10cm	20cm	30cm	etc.
0.1cm	0.2cm	0.3cm	etc.
1mm	2mm	etc.	
1/2m	1/4m	3/4m	1 1/2m etc.
50cm	25cm	etc.	

GAMES

(Playing in groups)

- 1) Place cards face up on the desk and spread out. Students take turns to pick matching pairs.
- 2) Place cards face down - play as in (1) but children select 3 cards, show to group, but must remember their position on the desk.
- 3) Let children make up or play their own card games e.g. Through the Pack. (A Vincentian Card Game)

Capacity

A selection of about ten containers of varying shapes and sizes is given to each group of between four and eight children. One of the containers should have a capacity of exactly one litre. Some water or sand is provided. Each group is asked to find a way of putting the containers in order of capacity.

After this has been done successfully - it will probably take some time - the teacher could draw attention to the litre container. The children could then be asked to draw an arrow diagram similar to this:

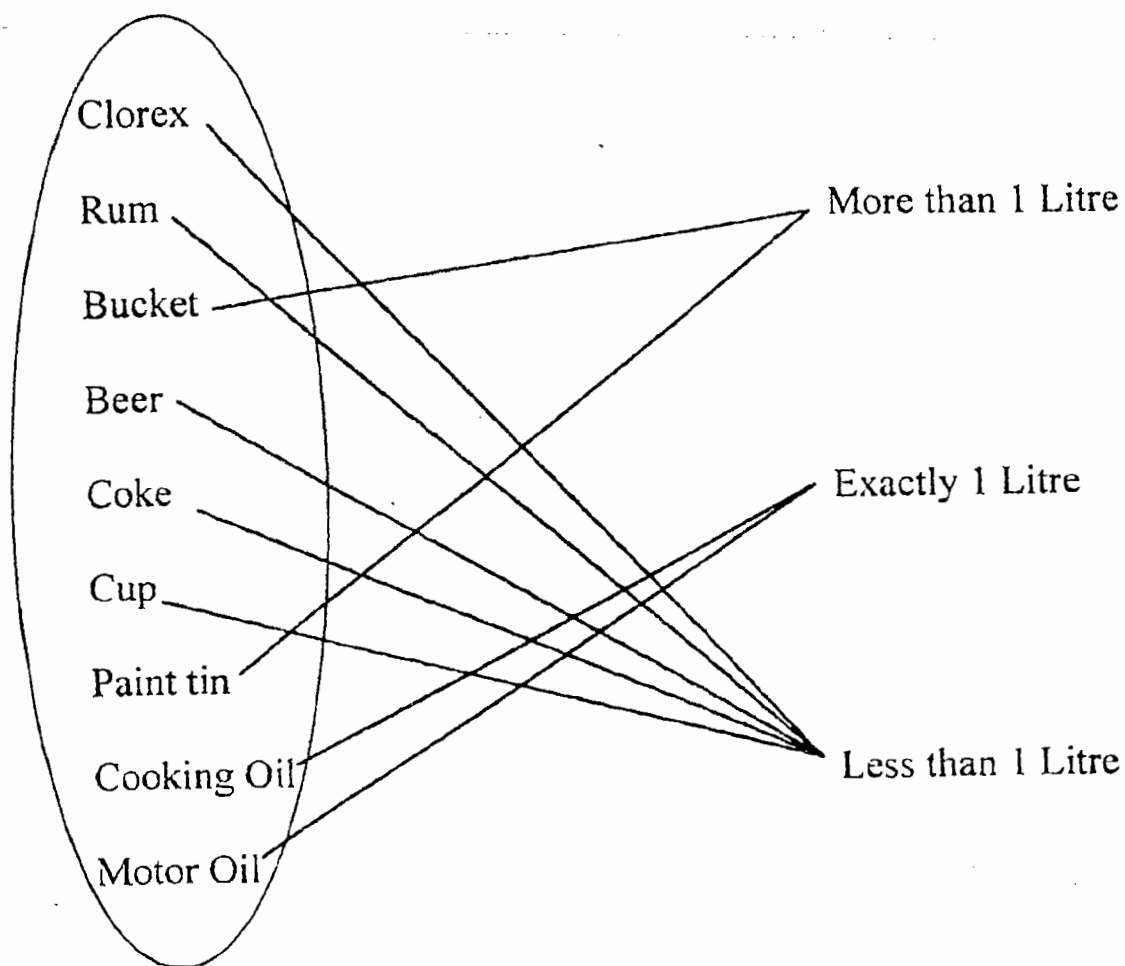

Mass

A selection of about ten objects of varying masses is given to each group of between four and eight children. One of the objects should have a mass of exactly one kilogram. Each group is asked to find a way of putting the objects in order of mass. (suitable balance scales can be used if available.

Pupils can estimate relative masses by holding and feeling the relative weights of the objects). After this has been done successfully - it will probably take some time - the teacher draws attention to the kilogram weight.

The children could then be asked to draw an arrow diagram like this.

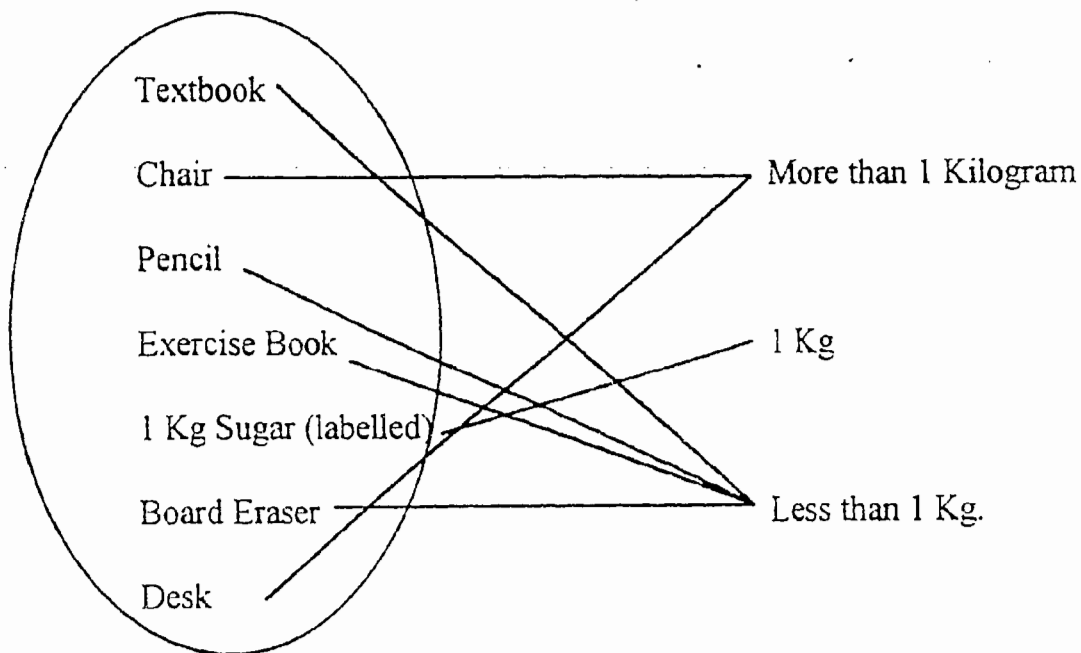

Metric Mass

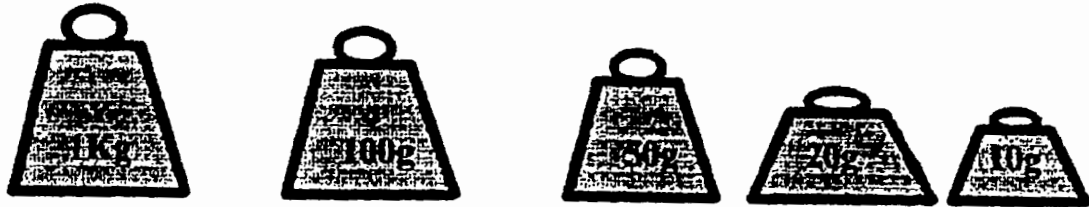

See if you can find something which weighs about 1 Kilogram.

Tick the masses you would use to weigh:

	100g	50g	20g	10g
40g flour			✓✓	
30g sugar				
60g tea				
130g butter				

Find some things to weigh in grams.

Estimate first, then weigh. Make a table like this:

Object	My Estimate	True Mass
Box	25g	35g

Now do these:

50g	20g	10g	\longrightarrow altogether weigh	<input type="checkbox"/>	50g
50g	20g	20g	\longrightarrow	<input type="checkbox"/>	50g
20g	20g	10g	\longrightarrow	<input type="checkbox"/>	50g
100g	50g	20g	\longrightarrow	<input type="checkbox"/>	50g

Make a collection of containers marked in grams



Weighing

6 Books.....gramsgramsgrams
A Skittle.....gramsgramsgrams
A Block of Woodgramsgramsgrams
A Brick.....gramsgramsgrams
A Football.....gramsgramsgrams

Time

Core Curriculum: 4.5 Time

Age Range: J4

Group Size: Individual/group

Objectives

To consolidate previous work on time; introduce the 24 hour clock; find the time in different time zones; and introduce the concept of using a calendar

Resources:

- An analogue and digital clock (if possible)
- A world map showing time zones / lines of latitude.
- Individual world maps for the students.
- Worksheets - see attached.

Previous Knowledge:

It is assumed that students are able to tell the time, if not some revision of this topic will be necessary.

Task:

1. Revise telling the time in hours and minutes.
2. Use sheet 1 to develop the concept of telling the time earlier and later.
3. Develop the concept of interpreting calendars, timetables, etc. using the attached sheets (2) - (9). Caribbean Primary Maths pp.70 - 72.

4. Introduce the concept of time zones. Use world maps and allow students to plot different time zones / lines of longitude. Plan a journey and monitor the different times in various places.
Could use the fact that many children have relatives in Canada and the UK as a basis for finding the time in those countries.

Important Points:

Theory of changing hours to minutes and vice versa can be introduced when the teacher feels it is necessary.

Further Activity:

- 1) Use local information to supplement the worksheets - students could collect information and make questions for other groups to answer.
- 2) Time Card Game - Matching different ways of writing the time. Prepare sets of cards e.g.

5.20

twenty past five

(as for measurement)

- 3) Time Word Search - prepare a grid using time words.

Time - How do you spend your day?

The children are arranged as groups of four.

- a) The teacher ask each group to work out how they spend each day
e.g. 8 hours sleeping, 1 1/2 hours eating.
They must make sure that the hours add up to 24 hours.
- b) When they have completed this they are asked to write the information up as a timetable.
e.g. 7.00 Get up and bathe
7.30 Eat breakfast
7.45 Leave for school.
- c) The answers to a) can be shown as a bar chart or pictogram.
- d) The timetable from b) can be used for children to ask questions of each other e.g.
"How long is it between getting up and going to school?"

Clocks

At least one child who can tell the time on a clock with hands are assigned to each group of four. Each group is given the materials to make a simple card clock. When the clock is made the able students then show the others how to tell the time and to test them with questions such as:

- (i) Show 4.00 on the clock.
- (ii) What time is shown on the clock?

This can be repeated with digital clocks and 24 hour clocks.

LOWER SCHOOL MATHS HOMEWORK -1

NAME.....GROUP..... DATE..... HAND IN BY

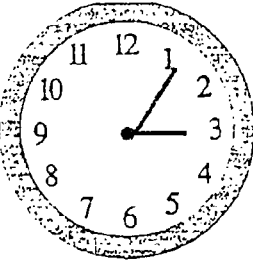
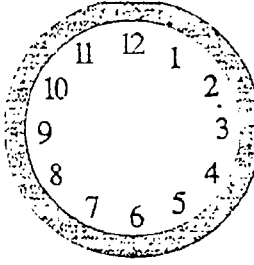
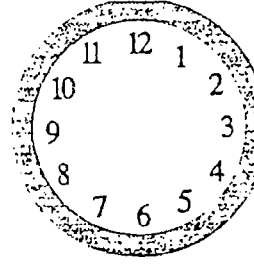
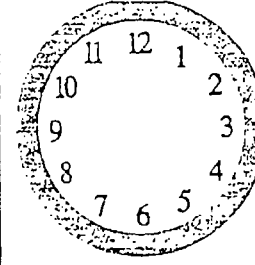
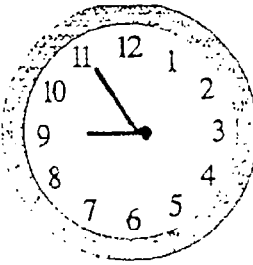
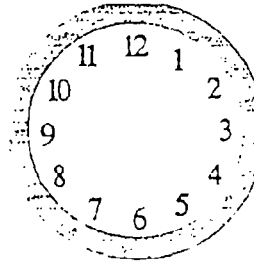
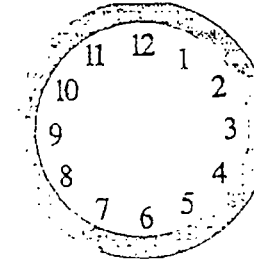
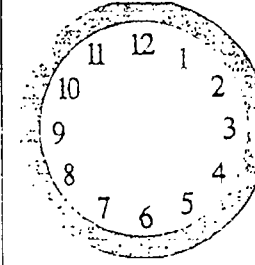
Write the time in words underneath each clock in this column.	Put the hands on the clock, then write the time in words underneath	Do the same as in column 2. Remember the hands have moved again.	Do the same again. Don't forget hands and words.
Column 1	Column 2	Column 3	Column 4
	 20 minutes later	 20 minutes later	 20 minutes later
	 20 minutes earlier	 20 minutes earlier	 20 minutes earlier

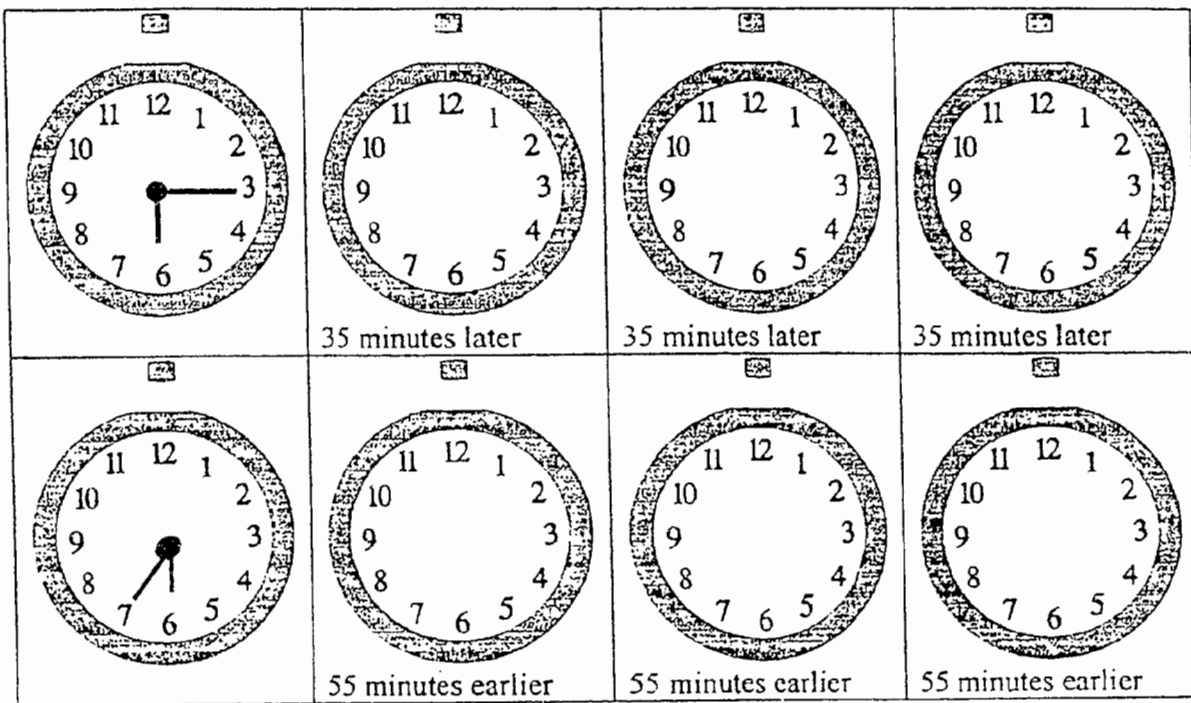

Since 1900 sixty eight species of mammals have become extinct.

On an earlier homework you were given the amazing fact that there are more than 10,000 minutes in a week.

On average each of us spends about $\frac{1}{3}$ of each day asleep.

Follow the following steps to work out exactly how many.

How many hours will you have spent asleep by the time you are 16?

How many minutes in one hour?

ANS

How many minutes in 6 hours?

ANS

How many minutes in 24 hours? (one day)

ANS

So how many minutes in 7 days? (one week)

ANS

SHOW ALL YOUR WORKING OUT AND EXPLAIN IT

ALWAYS TRY TO MAKE COMPLICATED CALCULATIONS EASIER BY DOING THEM STEP BY STEP.

BEST COPY AVAILABLE

Please ask anyone who's around if you need help with this homework.

LOWER SCHOOL MATHS HOMEWORK -3

NAME _____ GROUP _____ DATE _____ HAND IN BY _____

Read the newspaper article carefully then answer the questions.

DERBY EVENING TELEGRAPH,
Thursday, October 20, 1988

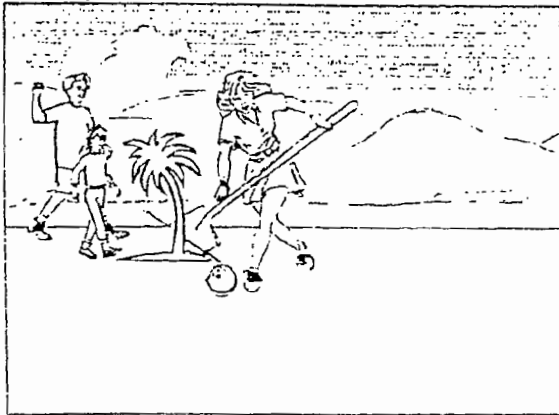

Miss Bowker plants one of the trees with Matthew Spencer (11) the oldest pupil at the school and Rosanna Barber (5) the youngest.

The roots of retirement

TEACHER Joyce Bowker presented three young trees to St John Fisher RC Primary School in Alvaston to mark her retirement after 32 years.

All the school's 200 pupils turned out to say thank you to Miss Bowker and to wish her a long and happy retirement.

Miss Bowker (58), of Old Hall Avenue, Alvaston, presented one of the trees in memory of Canon Christopher McKeown, a former parish priest in Alvaston who died several years ago.

She donated another to Shella Lemagnen, a former teacher, who died last year.

The third tree was on her own behalf.

After the planting ceremony Miss Bowker was given a surprise treat when the children presented her with a telephone stool as her retirement gift.

Tonight she is going to a second ceremony, this time attended by parents of children she has taught.

Miss Bowker said: "I've thoroughly enjoyed my career at the school and the children have all been fantastic."

1. How long was Joyce Bowker a teacher at St. John Fisher School?

2. Which year did she start teaching at the school?

3. How old is Joyce Bowker? _____
Which year was she born? _____
4. How old was she when she started teaching at the school?

5. Which year was Matthew Spencer born? _____
Which year was Rosanna Barber born? _____

If you feel you need any help do ask anyone who's around.

LOWER SCHOOL MATHS HOMEWORK -4

NAME _____ GROUP _____ DATE _____ HAND IN BY _____

21st
Congratulations Pete
21st birthday -
Andres xx

60th
Fred - Have a
birthday (tomorrow)
and the best wishes
Your ever loving
Dorothy xxx

UR 18
Chris - Congratulations
your 18th. I love you
Sandra xxx

80th
Phyllis - To a dear mum and
grandma on her 80th
birthday. Health and
happiness always. - Love
Pam, Terry and Family. xxxx

1. When was Pete born? _____
2. When was Fred born? _____
3. When was Chris born? _____
4. When was Phyllis born? _____

On the 1st February 1989:-

Sir Stanley Matthews was 74. When was he born? _____

Peter Sallis was 68. When was he born? _____

Don Everly was 52. When was he born? _____

Terry Jones was 47. When was he born? _____

Lisa Presley was 21. When was she born? _____

In which year will:-

Sir Stanley Matthews be 80? _____

Peter Sallis be 75? _____

Don Everly be 63? _____

Terry Jones be 72? _____

Lisa Presley be 42? _____

In which year was:-

Sir Stanley Matthews 50? _____

Peter Sallis 32? _____

Don Everly 21? _____

Terry Jones 29? _____

Lisa Presley 13? _____

How old was:-

Sir Stanley Matthews in 1940? _____

Peter Sallis in 1950? _____

Don Everly in 1938? _____

Terry Jones in 1957? _____

Lisa Presley in 1973? _____

Which of the five people were alive:-

When Mount Everest was first climbed?

The Titanic Sank?

The Berlin Olympics were held?

The First World War occurred?

The Second World War occurred?

If you need any help with this homework ask anyone you feel can help you.

LOWER SCHOOL MATHS HOMEWORK -5

NAME _____	GROUP _____	DATE _____	HAND IN BY _____
------------	-------------	------------	------------------

16 November **WEDNESDAY**

Its easy to see that ITN Morning News lasts for 1 hour. Its starts at 5.00am and finishes at 6.00

There are only four other programs which are exactly 1 hour long.

Find them and write them in this table:-

Programme	Start	Finish
ITN Morning News	5.00am	6.00am

There are a lot more programmes which are half an hour long. See how many you can find. Write them in this table.

Programme	Start	Finish

At a glance
ITV

- 5.00am ITN Morning News
- 8.00 TV - am
- 9.25 Lucky Ladders
- 9.55 Central News
- 10.00 The Time
- The Place
- 10.40 This-Morning
- 12.10pm Allsorts
- 12.30 Home Cookery Club
- 12.35 The Young Doctors
- 1.00 News at One
- 1.20 Central News
- 1.30 Heirloom
- 2.00 Richmond Hill
- 2.55 Gardening Time
- 3.00 Give Us A Clue
- 3.25 Central News
- 3.30 Sons and Daughters
- 4.00 The Raggy Dolls
- 4.10 The Rattles
- 4.20 Dogtarian and the Three Musketeers
- 4.50 Palace Hill
- 5.15 Blockbusters
- 5.45 ITN News
- 6.00 Central News
- 6.30 Emmerdale Farm
- 7.00 This-Is Your Life
- 7.30 Coronation street
- 8.00 Des O'Conner
- 9.00 The Equalizer
- 10.00 News at Ten
- /b Central News
- 10.35 The Kennedy Debate
- 11.45 Donahue
- 12.45am Film: Samurai
- 2.05 Superstars of Wrestling
- 3.00 The Twilight Zone
- 3.30 The Concert
- 4.30 Central Jobfinder '88

Complete this table.

In the last column write how long each programme lasts.

Programme	Start	Finish	Length
The Raggy Dolls			
News at Ten f/b Central			
Dogtanian and the 3 M's			
Give us a Clue			
Richmond Hill			
Blockbusters			
Allsorts			
The Young Doctors			
The Kennedy Debate			
Donahue			
Palace Hill			
Film: Samurai			

If you need any help with this homework do ask anyone who's around.

LOWER SCHOOL MATHS HOMEWORK -6

NAME _____ GROUP _____ DATE _____ HAND IN BY _____

Films

Complete the table, one has been done for you.

The Old Sorceress and the Valet

C4. 11.20am-12.50am
The second of two films by Julius Amyral about his first feature film. A strange and disturbing tale about an elderly Marquis and his valet who come to 20th century London. The valet is a wizard. But are they quite what they seem? Cover art included. 1987

Express the Terror

ITV. 2.30pm-4.00pm
Fast pace futuristic thriller directed by Curtis Appera. An extraordinary conceived superbly with high-tech club and a superb cast. Not quite as good as the intended series, but a jolly ride nonetheless in the company of a host of familiar faces. 1979

The Battle of the River Plate

C4. 2.50pm-5.05pm
A Royal performance film which aroused a certain amount of criticism from those who thought that in a war movie was too outlandish. It came in 1955 to see before the public. Anthony Quayle is the main watch for acting honours. It is excellently made story of how the British finally caught up with the German battleship Graf Spee. 1955

The Man Upstairs

C4. 2.00pm-3.40pm
Richard Attenborough's featured performance as the suicidal central figure of this tense and well-written drama opened up a new world for him as a director. He gained a major star. Bernard Lee is also good as the policeman who tries to save him. 1951

Film	Begins	Finishes	Lasts for -
1	2.00pm	3.40pm	1 hr 40 mins
2			
3			
4			
5			
6			
7			
8			
9			
10			

The Betsy

ITV. 12.55am-3.15am
Harold Robbins' books simply don't let themselves to great movies. With its expletives and noir style, this glossy saga of wheeling and double-dealing in the American Motor Industry would fit snugly into the mini-series format. 1977

The Big Parade

C4. 2.00pm-4.40pm
Enormously successful war film - expensively made for almost half a million dollars. It grossed four million dollars at the box office at the time - which deservedly costarred King Vidor as a top director. Originally made in black and white with some colour sequences.

Lament to a Live Microphone

C4. 11.00pm-11.20pm
The first of a series of films from Martinican director Jules Améde Loeb. It is an angry short about a young black man whose parents are murdered by racists in Paris. A compelling and emotional vignette. 1984

The House of the Yellow Carpet

ITV. 12.30am-2.15am
Believe nothing you think you see in this black comedy drama and you will enjoy an entertaining hour and a half of it with a quartet of actors headed by Brian Johnson, one of Norman Berkman's regular company of film actors. 1983

Pearl of the South Pacific

ITV. 1.30pm-3.00pm
Technicolor tale of the South Seas really. It stars with Dorothy Dand and her songs in the film. This bright yarn was one of the end of the cycle and contains all the familiar elements. 1955

Asylum

ITV. 12.30am-2.10am
Compilation series of films about the cinema of the sixties and seventies, but this is about the sixties and has suitably some performances by Robert Powell and Patrick Magee. It's better. 1972

List the titles of the films in order. Start with the oldest film.

A. _____

B. _____

C. _____

D. _____

E. _____

F. _____

G. _____

H. _____

I. _____

J. _____

Which films were made more than 20 years ago?

Which films were made more than 15 years ago?

Which films were made less than 10 years ago?

Which films were made less than five years ago?

Please ask your mum or dad for help, or anyone who's around - if you need it.

LOWER SCHOOL MATHS HOMEWORK -7

NAME _____ GROUP _____ DATE _____ HAND IN BY _____

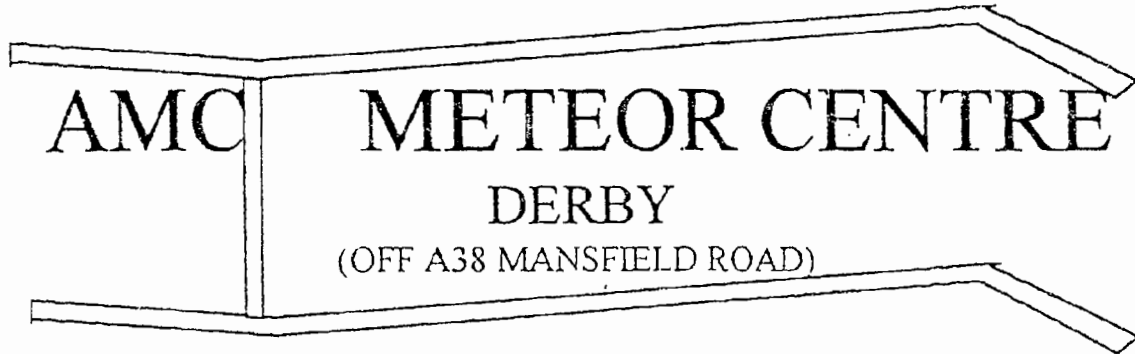

PLEASE NOTE THAT ALL FILMS START AT ADVERTISED TIMES
* 10N TIME INDICATES TWILITE SHOWS

BEETLEJUICE (15) 1 hr 40 mins (15)
2.15, (5.45), 7.55, 9.55

COMING TO AMERICA (15) 2 hrs (15)
1.55, (4.45), 7.15, 9.35

A FISH CALLED WANDA (15) 1hr 55mins (15)
2.05, (5.15), 7.35, 9.45

SHOW TIME AND THE SEVEN DWARFS(U)
1hr 25mins
1.15, 3.05, (5.15), 6.55, 8.35

WHO FRAMED ROGER RABBIT(PG)
1 hr 50 mins
1.35, (4.35), 7.05, 9.15

BUSTER (15) 1 hr 50 mins (15)
1.45, (5.25), 7.35, 9.45

GOOD MORNING VIETNAM (15) (15)
2 hrs 05 mins
1.55, (4.35), 7.05, 9.25

BIG (PG) 1 hr 50 mins (PG)
2.25, (5.55), 7.55, 9.55

SCROOGED (PG) 1hr 50 mins (PG)
2.15, (4.55), 7.25, 9.35

1. Which film lasts 1 hr 40 mins? _____

2. How many films last 1 hr 50 mins? _____

3. Which film lasts the longest?
_____ How long? _____

4. Which film lasts the shortest?
_____ How long? _____

5. Which film is shown 5 times each day?

6. How many films last more than two hours?

7. How many films last less than two hours?

8. How many films last between 1 and 2
hours? _____

9. How many films last between 2 and 3 hours? _____

Make up your own question for number 10.

10.

COMING TO AMERICA lasts for 2 hrs

It is on times each day.

Each day it is shown for

$$2 \text{ hrs} + 2 \text{ hrs} + 2 \text{ hrs} + 2 \text{ hrs} = 8 \text{ hrs}$$

Do the same for these films:-

1. BIG lasts for _____

It is on times each day

Each day it is shown for

2. BEETLEJUICE lasts for _____

It is on times each day

Each day it is shown for

3. SNOW WHITE AND THE SEVEN DWARFS LASTS FOR _____

It is on times each day.

Each day it is shown for

Jack and Jill were born on the same day, in the same year and have the same parents, but they aren't twins. How come?

If you need help ask anyone who's around

LOWER SCHOOL MATHS HOMEWORK -8

NAME _____ GROUP _____ DATE _____ HAND IN BY _____

MARCH

Eastgate Street, Staff Stafford ST16 2LT 84

Box Office 54653

Open MON-SAT 10AM-5 PM

Thurs 1st	7.30pm The Gatehouse STEELEYE SPAN Tickets £4.50	Mon 12th	7.45p.m. The Gatehouse , VIN GARBUIT & JAKE THACKRAY Tickets from £1.20	How many different items were put on in March 1984? (Start counting with Steeleye Span.)
Fri 2nd	2.30p.m. & 7.45 pm. The Gatehouse JOHN MANN Britain's No. 1 Entertainment organists Tickets from 90p	Wed 14th	2.30p.m. The Gatehouse OLD TIME MUSIC HALL Tickets from 90p	How long did the 'Bavarian Cabaret Night' last for?
Sat 3rd	10.30 a.m. & 2.30p.m. Cabin Studio Theatre THE GREAT KOVARI'S MAGIC SHOW Tickets £2 Children's special	Thurs 15th	7.45p.m. The Gatehouse HUMPHREY LYTTELTON Tickets £4.50	How long is it between the two performances of 'The Grant Galactic Adventure'?
Sun 4th	3 p.m. The Gatehouse ENGLISH STRING ORCHESTRA Tickets from £1.80	Fri 16th	8p.m. -1 a.m. The Gatehouse BAVARIAN CABARET NIGHT Tickets £4.50 Double tickets£8 Super included	How long is it between the two performances of John Mann
Fri 9th	7.45p.m. The Gatehouse BAND OF H.M.LIFE GUARDS Tickets from £1.50	Wed 12st	7.30p.m. nightly the to Fri 23rd Gatehouse ZIGGER ZAGGER Peter Tersons dramatic play-Grass Roots Young People's Theatre Co. Tickets from £1.50	For how many days is 'Oklahoma' running?
Sat 10th	10.30a.m. & 7.30p.m. Cabin Studio Theatre THE GRAND GALACTIC ADVENTURE Tickets £2 Children's special	Fri 23rd	8.00p.m. nightly to Sat 24th Cabin Studio Theatre SPRING AND PORT WINE by Bill Naughton Tickets £1.50	If Steeleye lasts for 2 1/2 hours. at what time does it finish?
		Tues 27th	7.15p.m. nightly The to Sat 31st Gatehouse Stafford and District Amateur Operatic Society OKLAHOMA by Rogers and Hammerstein Tickets from £2.00	If 'Zigger Zagger' lasts for 2 hours, at what time does it finish?

If 'Oklahoma lasts for 3 hours, at what time does it finish?

If 'Spring and Port Wine' lasts for 3 1/2 hours, how long before midnight will it finish?

How much are:
three 90p tickets to see John Mann

John and Jones go to 'Spring and Port Wine'
(a) How much do they pay altogether?
(b) If they arrive at 7.50, how long do they have to wait for the show to start?
(c) They booked seats on the 17th March. What day was that?

Four tickets for 'The Great Kavari's Magic Show'?

two tickets for the English String Orchestra?

Phyllis, Jack, Sandra, Leslie, Mick, Wendy, Bob and Sal book up an afternoon's performance of 'The Great Kovari's Magic Show'.

five tickets for 'Spring and Port Wine'?

(a) How much do they pay altogether?
(b) How much change is there from 4 five pound notes?
(c) If they are ten minutes late, what time do they get there?

five 90p tickets for 'Old Tyme Music Hall'?

Janet, Jane, Rosemary and Jean are all fond of jazz. they book tickets for Humphrey Lyttelton on March 15th.

(a) How much do they pay altogether?
(b) If they arrive for the show 15 minutes early, what time do they get there?

Mr and Mrs Jones book tickets for the English String Orchestra.

(a) If they pay £1.80 each, what does it come to?
(b) They are half an hour late for the show. What time do they get there?

Time Lines

Sets of cards like those illustrated below could be made by the teacher in advance.

In the morning



Tuesday at school

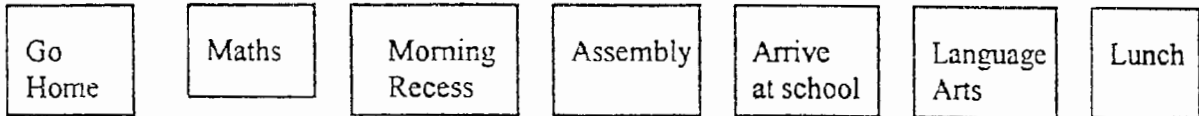

Life

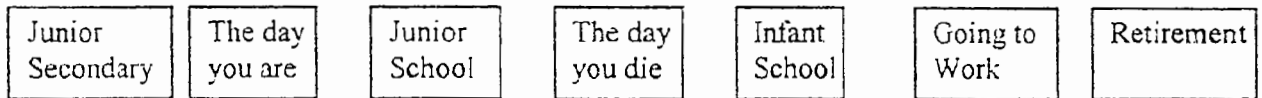

Cooking

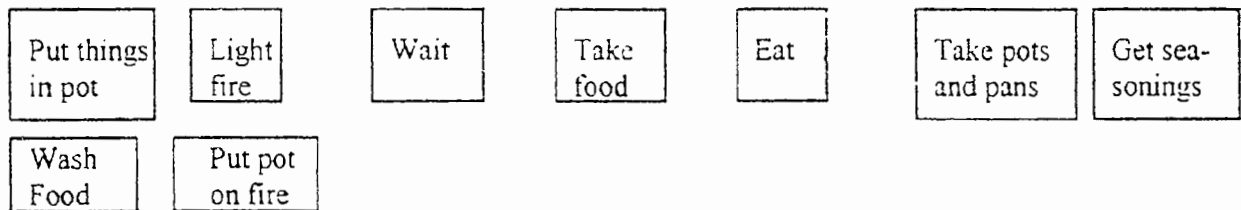

Each group of four children can be given a set of cards and they are asked to put them in order. The results can be recorded on one sheet of paper shared by the group. Groups can exchange sets of cards with each other as they finish. Afterwards each group could be asked to make a set of cards for another group to put in order.

Money

Core Curriculum: 4.6 Money

Age Range: J4

Group Size: Group/Individual

Objectives:

To revise addition and subtraction of money, pay bills in cash and by instalments.
Understand foreign currency

Resources:

Newspapers: for price lists.

Previous Knowledge:

Some previous knowledge of 4 rules of money is assumed.

Tasks:

- 1) Let children discuss and list prices of objects/food, etc.
- 2) Develop shopping lists from the information in (1) and calculate total price, change from \$10, \$20, \$50 etc.
- 3) Use the prices of more expensive goods to discuss payment by instalments. Compare exact and increased prices and discuss with the children.
- 4) Again using the prices of more expensive goods discuss the concepts of 'Profit' and 'Lost' then give examples.
- 5) Relate all/some of the above work to foreign currency - what would the prices be in US\$. £ Sterling, French Francs, Venezuelan bolivars.
(Contact the banks for the currency exchange rates).

Important Points:

This work is generated from real-life situations where children have found prices for themselves - these prices have been used as a basis for all this work.
If examples (e.g. boxes, bottles, packets) can be brought into school and prices added - make this into a display Children will 'play' and do lots of maths outside the formal maths lesson.

Further Activity:

- 1) CPM. Bk6. lessons 16. 17. 18
- 2) Translate the problems in CPM (as above) into foreign currency.
- 3) Include work from the supplementary Objectives Section in this 'Money' section e.g. discounts. sale prices.

St. Vincent and the Grenadines
Mathematics

Core Curriculum Outline
10 - 11+ Year Olds

- 5.0 SETS
- 5.1 Identify equal sets
- 5.2 List proper subsets from given data
- 5.3 Use the symbol for 'is a subset of'
- 5.4 Use Venn diagrams to show intersection, not > 2 sets
- 5.5 Solve problems using Venn diagrams.

Sets

Core Curriculum: 5.0 (sets)

Age Range: J4

Group Size: Class and individual

Objectives:

To extend students' knowledge of sets, introducing the concepts of equal sets, subsets, and Venn diagrams.

Resources:

Paper and pencil.

Previous Knowledge:

None

Task:

- 1) Ask 5 or 6 pupils to draw some pictures on the blackboard. Students identify various sets, e.g. animals, wheels, circles, etc.
- 2) Use the pictures on the board to represent a set - introduce the notation of a Set of Pictures = {pictures} i.e. use of curly brackets. Introduce the notion of {wheels}, {circles}, etc. as subsets. Ask students to list their own sets from the {pictures}
- 3) Ask students to identify elements of other sets e.g.:

{Days of the week}, {Months beginning with the letter J}, etc. and write these using the correct notation.

- 4) Give examples of equal / unequal sets to show that:
 $\{a,b,c,d,e\} = \{\text{first 5 letters of the alphabet}\}$, etc.
- 5) Introduce the concept of a set being represented within a circle - as an introduction to Venn Diagrams. Draw some sets from the above examples within circles.
- 6) Draw two large intersecting circles on the playground/classroom floor. Ask the girls to stand in one circle, the boys in another. Question why no-one is in the intersection. It should quickly become obvious that no-one is both boy and girl!
- 7) Use other examples to develop the concept of intersection, still ask students to stand in the two large circles on the floor e.g.:
Students with brothers, sisters, brothers and sisters.
Students who ate tea, porridge, both for breakfast.
- 8) These practical examples lead naturally to drawing Venn Diagrams. Draw examples using the names of the students from above.
- 9) Complete the topic giving pairs of sets to be written as Venn Diagrams, e.g.:
 $\{\text{first 5 even numbers}\}$, $\{1,2,3,4,5\}$
 $\{\text{first 5 letters of the alphabet}\}$, $\{\text{Letters in the word 'cat'}\}$

Important Points:

The practical activities provide an understandable introduction to these concepts and should not be underestimated.

Further Activity:

The work outlined above satisfies the objectives of the curriculum for Junior 4.

ε :

Sets - Venn diagram

Use different groups of objects and classify them as below.

Venn diagram

curved

straight

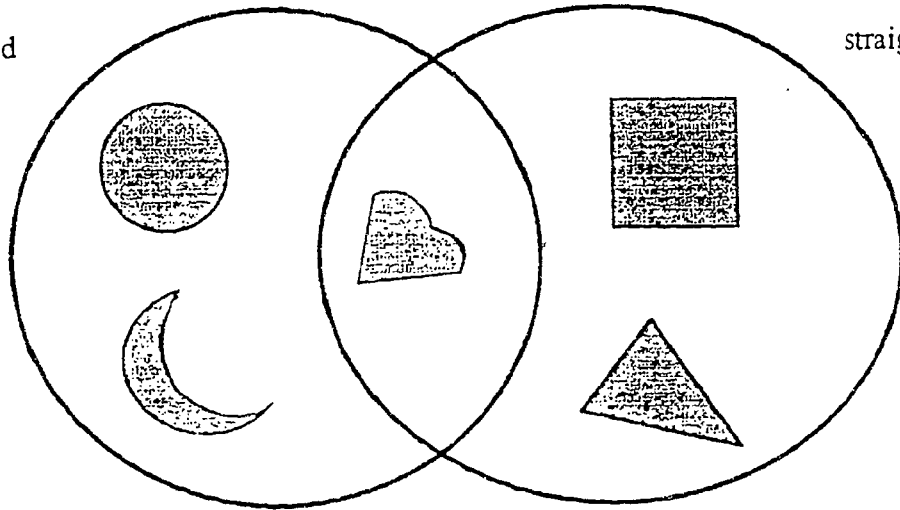

Where do these shapes go in the diagram?

Draw them in the right place.

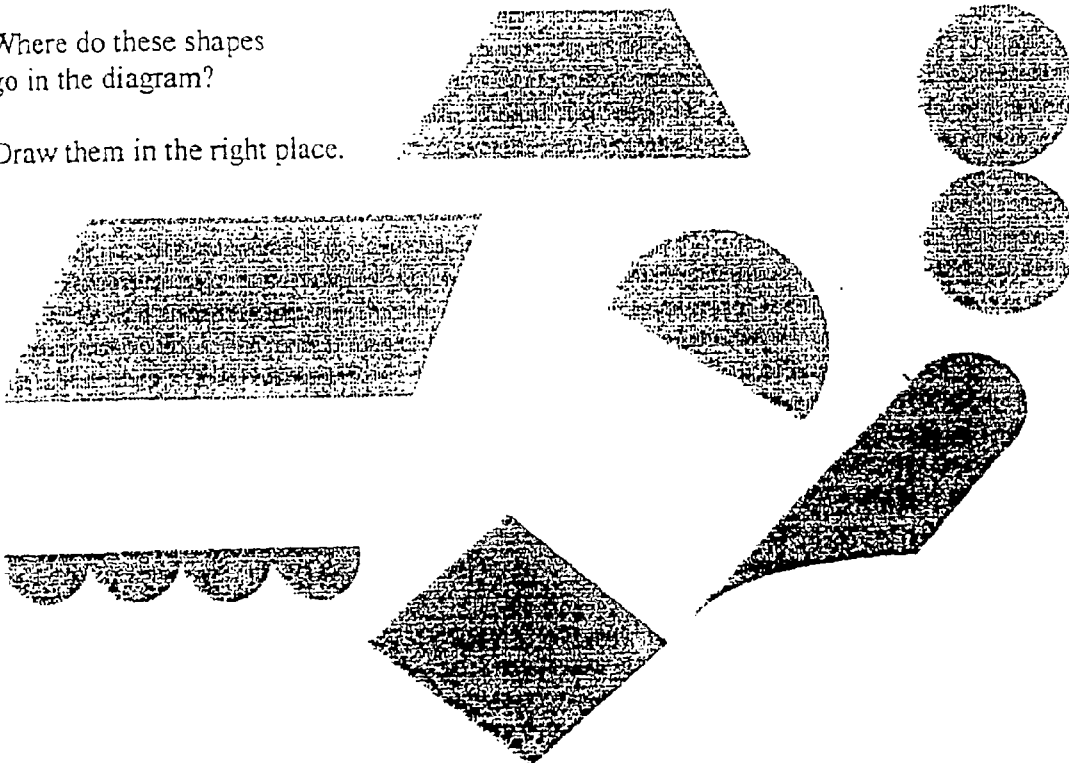

e.g. classify by colour (red objects, yellow objects, red and yellow objects); by movement (does it roll, stand upright, both?) etc.

St. Vincent and the Grenadines
Mathematics

Core Curriculum Outline
10 - 11+ Year Olds

- 6.0 Fractions
- 6.1 Find fractional parts of given quantities.
- 6.2 Find sets of equivalent fractions
- 6.3 Pick out lowest term fraction from a set of equivalent fractions.
- 6.4 Write a given fraction in lowest terms
- 6.5 Add and subtract fractions with like and unlike denominators
- 6.6 Add and subtract mixed numbers
- 6.7 Change improper fractions to mixed numbers and mixed numbers to improper fractions.
- 6.8 Multiply a fraction by a whole number, and a whole number by a fraction.
- 6.9 Multiply a fraction by another fraction
- 6.10 Divide a whole number by a fraction
- 6.11 Divide a fraction by a fraction
- 6.12 Order and compare fractions
- 6.13 Solve word problems involving fractions.

Fractions

Core Curriculum: 6.0 Fractions

Age Range: J4

Group Size: Individual/group activities

Objectives:

To develop the concept of equivalent fractions, perform the rules on fractions and solve word problems which involve fractions.

Resources:

Multilink Cubes plus Worksheets: Early Ideas and Equivalence.
Fraction strips and circles
Fraction problems using geometric shapes
Fraction cards

(See attached for examples of these sheets)

Previous Knowledge:

It is assumed that students will be familiar with the concept of fractions and will have some basic skills in manipulating fractions.

Task:

- 1) Use multilink cubes plus relevant cards to make fractional shapes each showing equivalent fractions. ('Early Ideas' SY497/8)
Students should work in groups to foster discussion on each individual's work.
- 2) Use fraction strips and circles to develop the concept of equivalent fractions, comparison of fractions, i.e. $>$ or $<$ and for showing simple addition.
- 3) Use the 'fraction tree' worksheet to further demonstrate and reinforce the concept of equivalence.
- 4) CPM Bk 4, lesson 24 develops the concept of numerator and denominator, for comparison of fractions.
- 5) Once these concepts have been introduced some formal teaching of the four rules could take place - egs. in CPM Bk 4, lessons 28 to 32. Lessons 47 and 116 extend this work.
- 6) Fraction card games - further work on equivalence - make sets of equivalent fractions (see section on measurement for ideas).
- 7) Fractions maze (see attached sheet).

Important Points:

These are some of the activities which give practical experience of using fractions. The work builds on the work done by more formal teaching without the need for children doing endless exercises in addition, subtraction, etc. of fractions.

Further Activity:

- 1) It is interesting to look for fractions around us e.g. flags
- 2) Let students develop their own games, diagrams etc.
- 3) See separate booklet on Fractions for further ideas.

Fractions

Preparation of teaching materials.

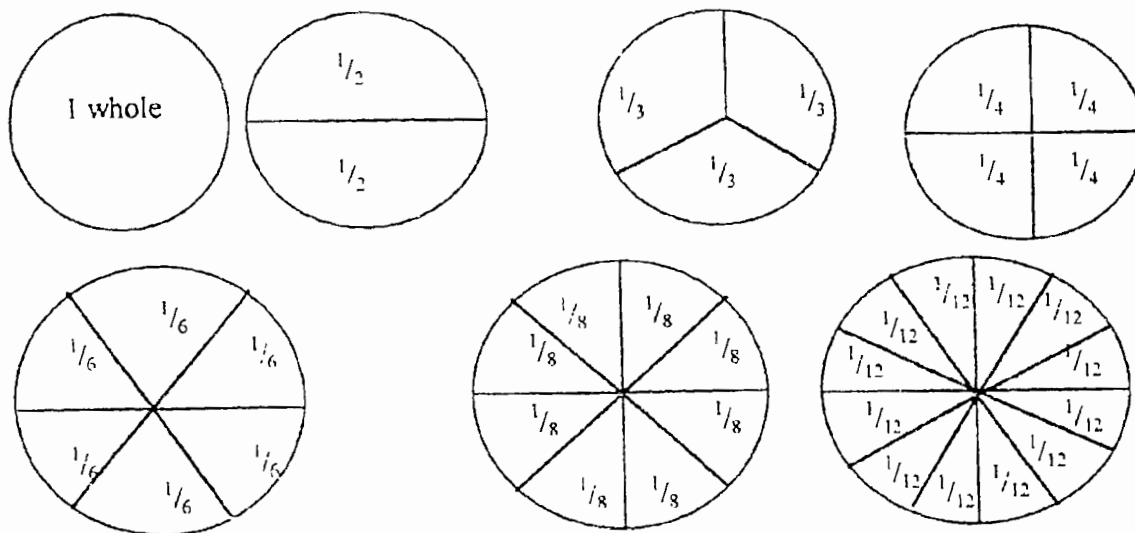

Cut out seven circles (approximately 20cm diameter) from stiff card.
Carefully mark them in the way illustrated above.
Cut along all the lines to give wedge pieces.

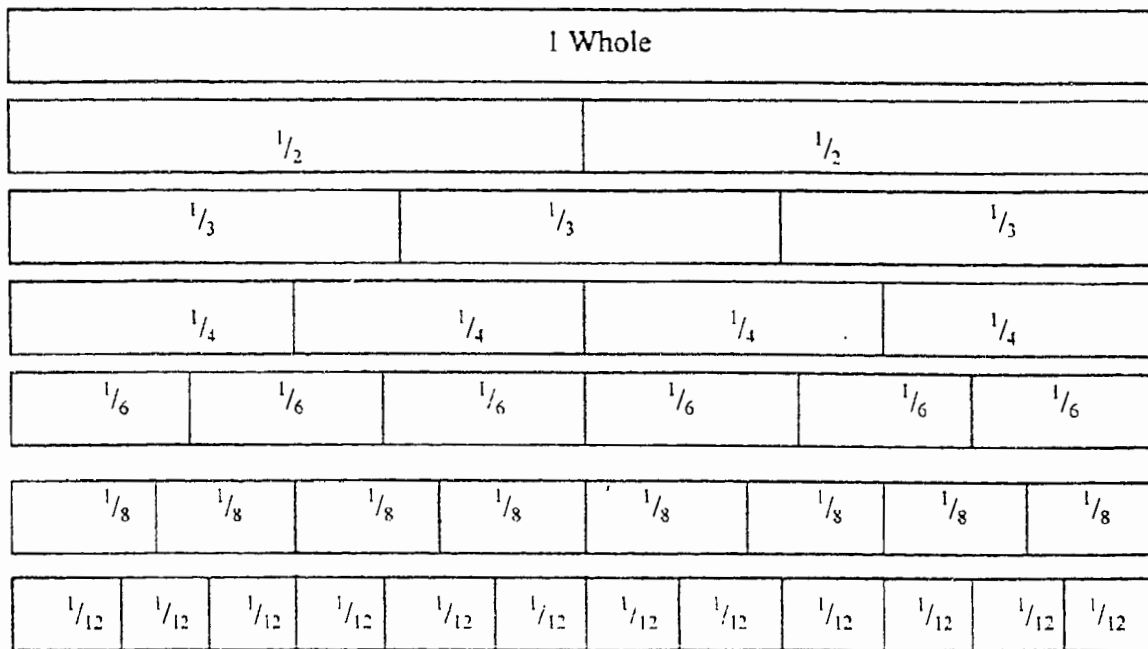

Cut out seven strips marked as illustrated (24 x 2cm). Each complete set of cardboard pieces should be adequate for about eight children. Again the sharing of pieces will encourage discussion:



- a) Fraction equivalent to one whole
- b) Fractions equivalent to one half.

- a) One set of wedge pieces is mixed up and given to each group of eight. The teacher asks the children to use the pieces (which are mixed up) to make 'wholes' and should then be left to work independently. Eventually, with teacher assistance if necessary, the circular arrangements as illustrated on the previous page will be made.
- b) When completed the teacher asks for each group to show a half. The teacher asks that the circles are broken and that the children now find ways of making a half. One piece of paper is given to each group so that results are recorded. Each group is asked to try and find all the possibilities. When this has been done the teacher asks for those that have been found and writes them on the board. The wedges are now collected and the rectangular strips are distributed. The activities are repeated with these pieces

A set of wedge-shaped pieces are given to each group of eight. The teacher asks for each group to show a half. Each group is then asked to find fractions that are bigger than a half. Only pieces of the same size can be put together.

A sheet of paper is given to each group for the recording of results. The children should be encouraged to find as many as they can. When all or most of the possibilities have been found, the teacher can collect them and write them on the board. The children are now asked to find fractions smaller than a half. Again they should try and find all of the possibilities.

At no point has the fraction notation been explicitly used except in labelling the individual pieces. However, the teacher can use it as she collects answers at the board. For example, if a child says "three-sixth", the teacher can write it as $\frac{3}{6}$. For most children in grades 6 or 7 this should be sufficient.

For each fraction $\frac{3}{8}$ a complement in 1 can be found
 E.g. For $\frac{3}{8}$ we could have $\frac{5}{8}$ Since $\frac{3}{8} + \frac{5}{8} = 1$.

The children are asked to find the complement in 1 of all the fractions found. Exercises like these could then be set.

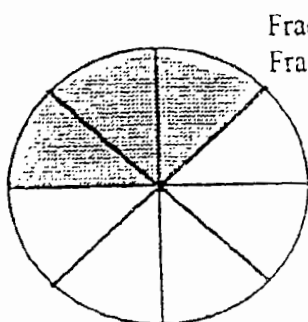

Fraction shaded is _____
 Fraction unshaded is _____

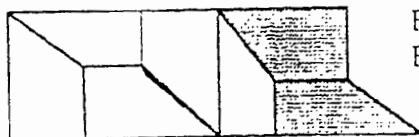

Fraction shaded is _____
 Fraction unshaded is _____

This could be followed by some simple addition and subtraction exercises.

Fraction Tree Worksheet

Colour the fraction tree
What pattern can you find?

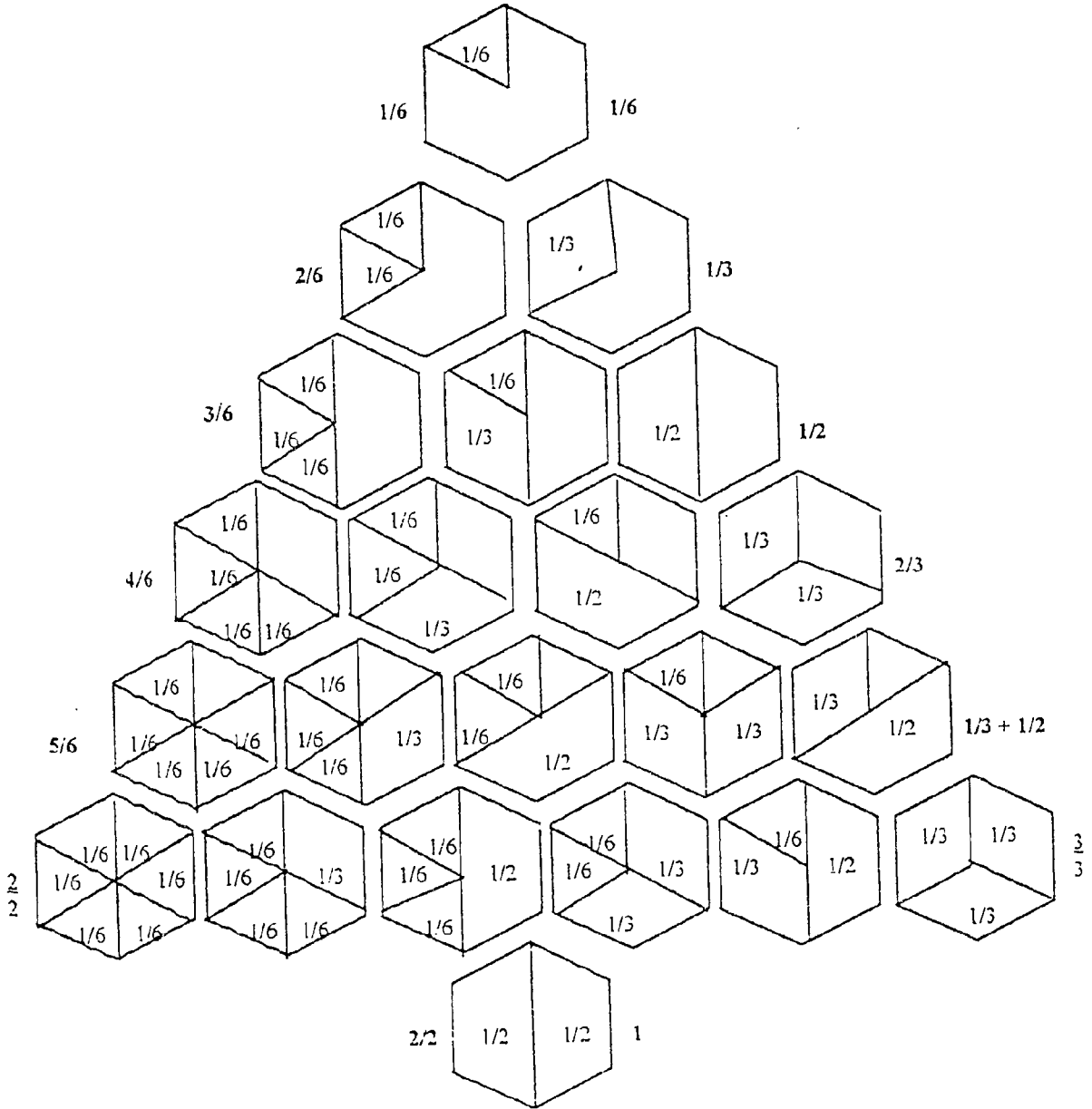

Fraction Maze

There are exactly 2 paths from the start to the finish which TOTAL 1

One has been started for you - can you complete it and find the other one?

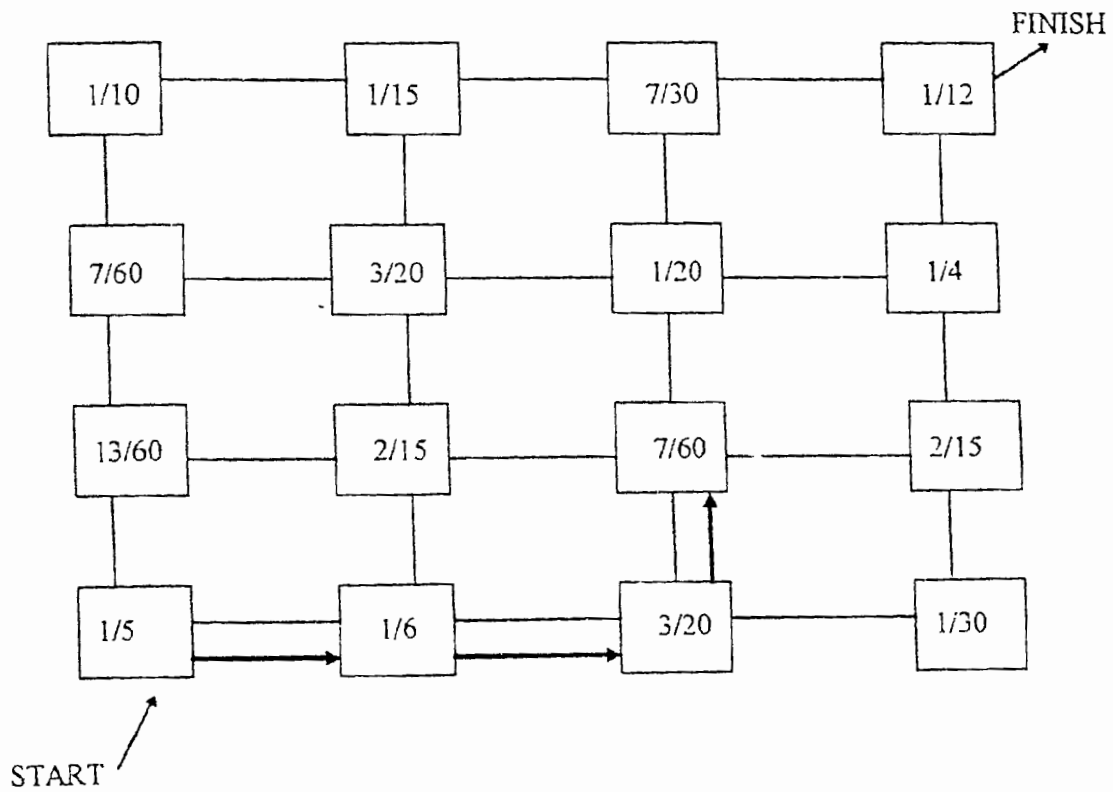

St. Vincent and the Grenadines
Mathematics

Core Curriculum Outline
10 - 11+ Year Olds

7.0 Decimal Numbers

- 7.1 Identify decimal fractions up to 1000's
- 7.2 Add and subtract decimal numbers up to 1000's
- 7.3 Multiply a decimal number by a whole number
- 7.4 Multiply a decimal by a decimal
- 7.5 Divide a decimal by a whole number
- 7.6 Divide a decimal by a decimal
- 7.7 Solve problems involving addition, subtraction, multiplication and division of decimal numbers.
- 7.8 Order and compare decimals
- 7.9 Change common fractions to decimals and decimals to common fractions

Decimals

Core Curriculum: 7.0 Decimals

Age Range: J4

Group Size: Individual/group

Objectives:

To develop skills in handling decimal numbers and relating these to fractions.

Resources:

No special resources required.

Previous Knowledge:

Previous knowledge of fractions is assumed.

Task:

- 1) To introduce the concept of the value of the fractional parts of decimals:

	1000	100	10	1	.	1/10	1/100	1/1000
e.g. 24.35 =			2	4	.	3	5	
136.409		1	3	6	.	4	0	9

etc.

Give sufficient examples to ensure that pupils understand the significance of the decimal point and the value of the figures after the point.

- 2) Use the same table when adding and subtracting decimals - this ensures that the point is maintained in the correct position (a major problem when working with decimals).
- 3) Change fractions to decimals and vice versa.
- 4) Order decimals in relation to their size.
- 5) Perform the four rules of arithmetic with decimals.

Important points:

This topic forms a link with fractions and percentages - it may be advisable to teach these three topics consecutively.

Further Activity:

Further examples in CPM Bk6:

- i) pages 22-24, lessons 39-43, dec. notation, addition, subtraction.
- ii) page 25, practice and drill.
- iii) page 26, lessons 44-45, practice of above plus word problems.
- iv) pages 35-36, lessons 56-59, fractions to decimals and vice versa.
- v) pages 48-51, lessons 74-82, more decimals manipulation.
- vi) pages 76-79, lessons 117-122, 125-126, multiplication.
- vii) pages 85-87, lessons 131-135, division

If students have problems with decimals, link the work to money - this usually works!

St. Vincent and the Grenadines
Mathematics

Core Curriculum Outline

10 - 11+ Year Olds

- 8.0 Percentages, Ratio and Proportion
- 8.1 Find simple percentages of given quantities
- 8.2 Express a fraction as a percentage and / or decimal
- 8.3 Solve problems involving unequal sharing
- 8.4 Solve ratio problems using multiples of sets.

Percentage and Ratio

Core Curriculum: 8.0 Percentage and Ratio

Age Range: J4

Group Size: Class

Objectives:

To complete the work on fraction and decimals by linking to percentages and ratio.

Resources:

No special equipment required.

Previous Knowledge:

Fractions and decimals.

Task:

- 1) Introduce the concept of percentage as 'out of 100'.
- 2) Write percentages as fractions and decimals - use CPM Bk6, page 81-84, lessons 127-130, plus Practice and Drill.
- 3) Introduce ratio and proportion as a means of sharing in different quantities. Use CPM Bk6, pages 19-22, lessons 34-38.
- 4) Word problems are given in CPM Bk6 page 54, lessons 83-84 and page 72, lessons 110-111.

Important Points:

These topics should be grasped fairly quickly if pupils have a sound basis in fractions and decimals.

Further Activity:

Consolidate this work with a game of equivalence using fractions, decimals and percentages. Pupils are given cards containing different symbols, these are matched in pairs, each pupil taking a pair in turn. Turning the cards face down makes the game somewhat more difficult.

Ratio

Ratio is a type of unequal sharing. Quantities are divided in regular proportions. E.g. Put 12 mangoes in the ration 1:2

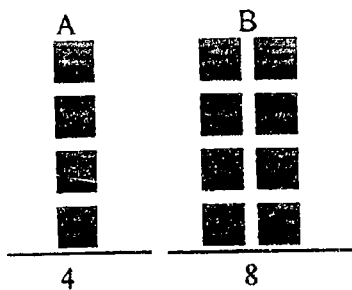

Each time group A has 1, Group B has 2. Therefore Group A has 4 mangoes and Group B has 8 mangoes.

Notice that 3 mangoes are shared each time.

A gets 1 out of 3 = $1/3$

B gets 2 out of 3 = $2/3$

SET IT DOWN LIKE THIS

No. of mangoes = 12

Ratio = 1:2

Shares = $1 + 2 = 3$

A = $1/3 \times 12 = 4$ mangoes

B = $2/3 \times 12 = 8$ mangoes

ONE SHARE TIMES ANOTHER

E.g. Put 24 eggs into 2 bags so that one contains three times as many as the other

Eggs = 24 Ratio = 1:3

Shares = $1 + 3 = 4$

1st bag = $1/4 \times 24 = 6$ eggs

2nd bag = $3/4 \times 24 = 18$ eggs

EXERCISES

1. Divide 40 plums between Kezi and Melissa in the ratio 2:3.
 - (a) Kezi gets _____ plums.
 - (b) Melissa gets _____ plums.

2. Nuala has 3 times as many pens as her twin brother Marcus. Together they have 80 pens.
 - (a) Nuala has _____
 - (b) Marcus has _____

3. At a party, each time Odini ate 3 sandwiches, Jarrand ate 2 and Miles ate 1. They ate 72 sandwiches in all.
 - (a) Odini ate _____
 - (b) Jarrand ate _____
 - (c) Miles ate _____

4. Mrs. Browne is twice as old as her daughter Simone. Their ages total 63. How old is Simone?

5. In a bag of 140 fruits there are 4 times as many cherries as oranges and twice as many cherries as limes.
 - (a) No. of cherries _____
 - (b) No. of limes _____

6. When sharing \$400 between two brothers one receives \$2 for each \$3 received by the other. If the money is shared giving the elder boy the greater amount, how much does the younger one receive?

7. When the younger one has \$80, how much would the elder have?

St. Vincent and the Grenadines
Mathematics

Core Curriculum Outline
10 - 11+ Year Olds

- 9.0 Graphs.
- 9.1 Read information from pictograms and bar graphs.
- 9.2 Choose a suitable scale to display data on pictograms and bar graphs.
- 9.3 Construct pictograms and bar graphs from given data.
- 9.4 Order events and dates on a time line.

Graphs

Core Curriculum: 9.0 Graphs

Age Range: J4

Group Size: Individual and group activity

Objectives:

To enable students to build graphs and read data from given graphs.

Resources:

Graph paper - 5mm or 10mm square is suitable.

Scraps of drawing paper and crayons for pictures to add to graphs.

Previous Knowledge:

Students should have some previous knowledge of drawing graphs and the sensible choice of scales.

Task:

1. Develop the concept of a tally chart by questioning the children about their favourite fruits, vegetables, drinks, lessons, etc. and developing tally charts in response to their preferences.
2. Students build graphs and pictograms by drawing fruits, drawing 'stick man' with their names on etc. These pictures are placed on the prepared grid, which should have an appropriate scale. If the class is divided into groups of 5/6 each group could take responsibility for producing one graph.
3. Further practice should be given using bar and line graphs. (Let the students decide their own topics to graphs).
4. To give practice at interpreting graphs use CPM Bk 4, lessons 48 to 56.

Important Points:

Drawing graphs can be a time consuming task, especially if students are to work in groups collecting data - as this is important to their basic understanding sufficient time should be allocated to this work. Some of the drawing for pictograms could be done in an art lesson if time is short.

Further Activity:

If the school is involved in 'chicken projects', etc. let groups of students monitor the progress/growth and graph the information. Other topics: school /class attendance/ term, exam marks, class marks, etc.

St. Vincent and the Grenadines
Mathematics

Core Curriculum Outline
10 - 11+ Year Olds

10.0 Problem Solving

- 10.1 Solve problems based on units of measurement involving addition, subtraction, multiplication and division.
- 10.2 Solve problems where a symbol represents a number.
- 10.3 Solve word problems involving these terms: total, sum, difference, product, less than, more than, times, altogether, in all, share, equally, each, fewer, least, most, fewest.

11.0 Supplementary Objectives

- 11.1 Tell, read and record the time using the 24 hour clock.
- 11.2 Use ordered pairs to find a position on a grid.
- 11.3 Calculate distances between given points on a map.
- 11.4 Interpret information from a map.
- 11.5 Identify pairs of parallel, intersecting and perpendicular lines.
- 11.6 Identify angles greater than or less than a right angle.
- 11.7 Calculate discount on given prices.
- 11.8 Find the sale price of an item given the rate of discount.
- 11.9 Calculate the interest on savings using simple interest.

Problem Solving

Give children a word problem and boxes

+	-	x	÷
---	---	---	---

There first task is to decide the operation which needs to be done - they then circle the box answering each question. This work is marked before children calculate the answer.

This exercise makes the children consider the actual problem and places less emphasis on achieving the answer.

Examples are given overleaf.....

NB. If students have difficulty solving word problems ask them to represent the problem by drawing a picture. This helps them to visualise the problem, then the mathematical question should be easily recognised.

(A) The 70 lorries on the road are loaded with bricks and bags of rice. 39 of them are loaded with bags of rice. How many lorries are loaded with bricks?

+	-	x	÷
---	---	---	---

Answer _____

(B) A rope 12 centimetres long is cut into two equal pieces. How long is each piece ?

+	-	x	÷
---	---	---	---

Answer _____

(C) A girl has three pieces of ribbon. The first piece is 80cm. The second piece is 1 m 10cm and the third is 1 m 25 cm. How many metres and centimetres of ribbon has she in all?

+	-	x	÷
---	---	---	---

Answer _____

(D) If there were 2 rows of children playing ball relay, and 14 children were in each row, how many were playing altogether?

+	-	x	÷
---	---	---	---

Answer _____

Supplementary Objectives

All supplementary objectives have been included in the appropriate section of this booklet except:

11.2 Use ordered pairs to find a position on a grid.

11.3

11.4

Calculating distances and interpreting maps.

Ideas for these are included here:

11.2 Ordered Pairs

Use squared paper for this work and ask children to label the areas with numbers 1-5 - emphasise the need to have equal intervals between the numbers.

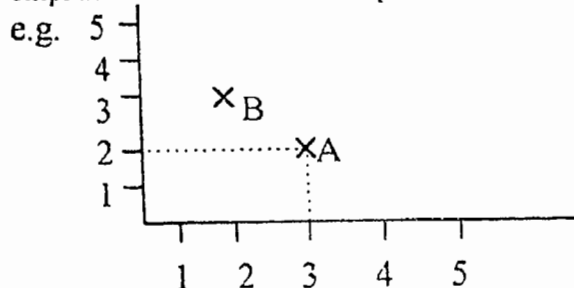

Discuss the location of a point, given a co-ordinate i.e. (3,2) is at point A not point B.

Give pairs of co-ordinates and ask children to mark the points and then join the points together in order.

i.e. (1,1) (5,1) (3,4) (1,1)

It should be fairly obvious if they have made an error!

Try the following:-

- 1) Axes from 1-8
Co-ordinates: (5,3) (2,3) (2,0) (5,0) (7,1) (7,4) (5,3) (5,0) stop
(4,4) (7,4) (8,6) (5,6) (4,4) (2,3) end.
- 2) Axes from 1-8
Co-ordinates: (4,7) (4,2) (1,2) (2,1) (7,1) (8,2) (4,2) stop.
(8,3) (1,3) (4,7) (8,3)
- 3) Let children devise their own shapes and give the co-ordinates to a friend to draw.

Further Activity

Use a grid which holds the letters of the alphabet, i.e.:

5	A	B	C	D	E	Use co-ordinates to give coded messages e.g. (3,4) (5,5) (2,3) (2,3) (5,3) Children love to make these for themselves.
4	F	G	H	I	J	
3	K	L	M	N	O	
2	P	Q/R	S	T	U	
1	V	W	X	Y	Z	
	1	2	3	4	5	

NB This work is ideal to leave as a classroom display.

Traveling 11.3 and 11.4

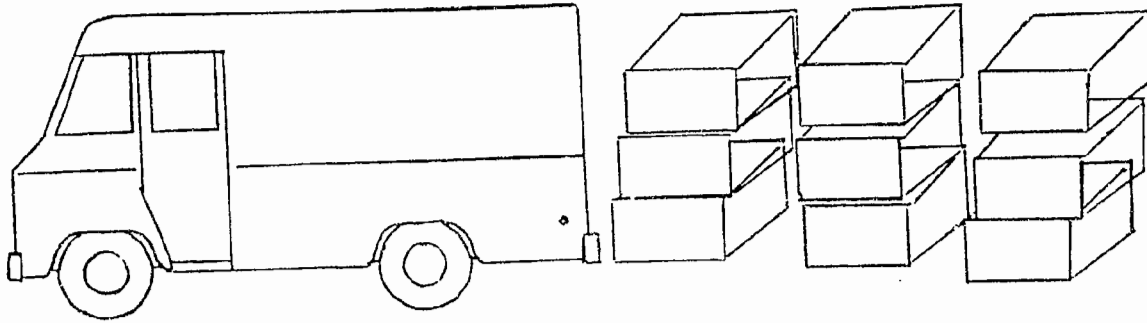

Fresh fruit is delivered by van every day to the towns of Gainsborough, Louth, Sleaford and Newark from a warehouse at Lincoln.

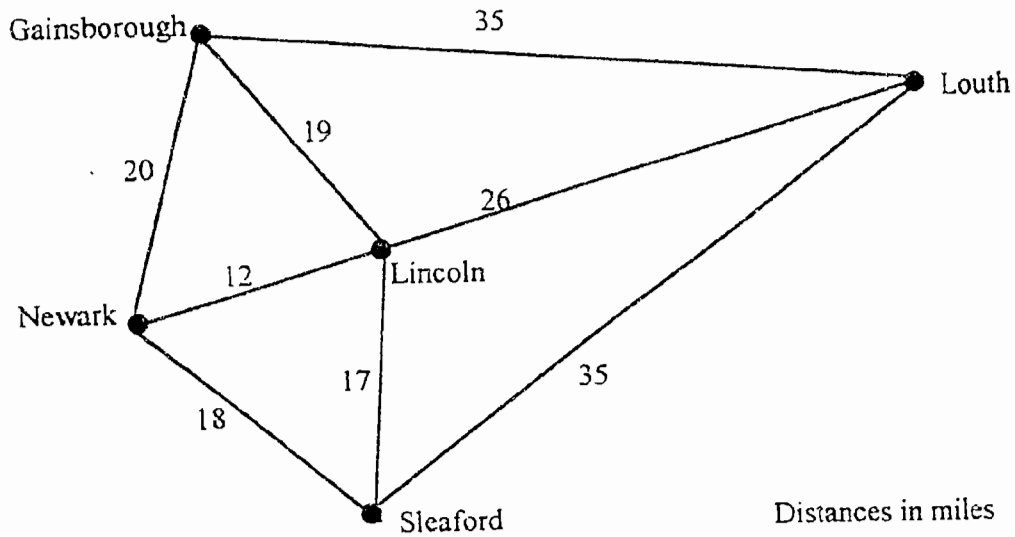

1. List a route which starts and finishes at the warehouse and visits all the towns.
2. What is the total length of your route?
3. Find a route of total length 116 miles.

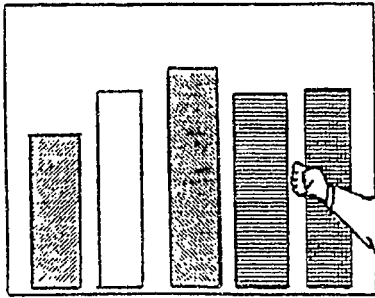

A computer salesman, who lives in London, wants to visit all the cities shown on the map.

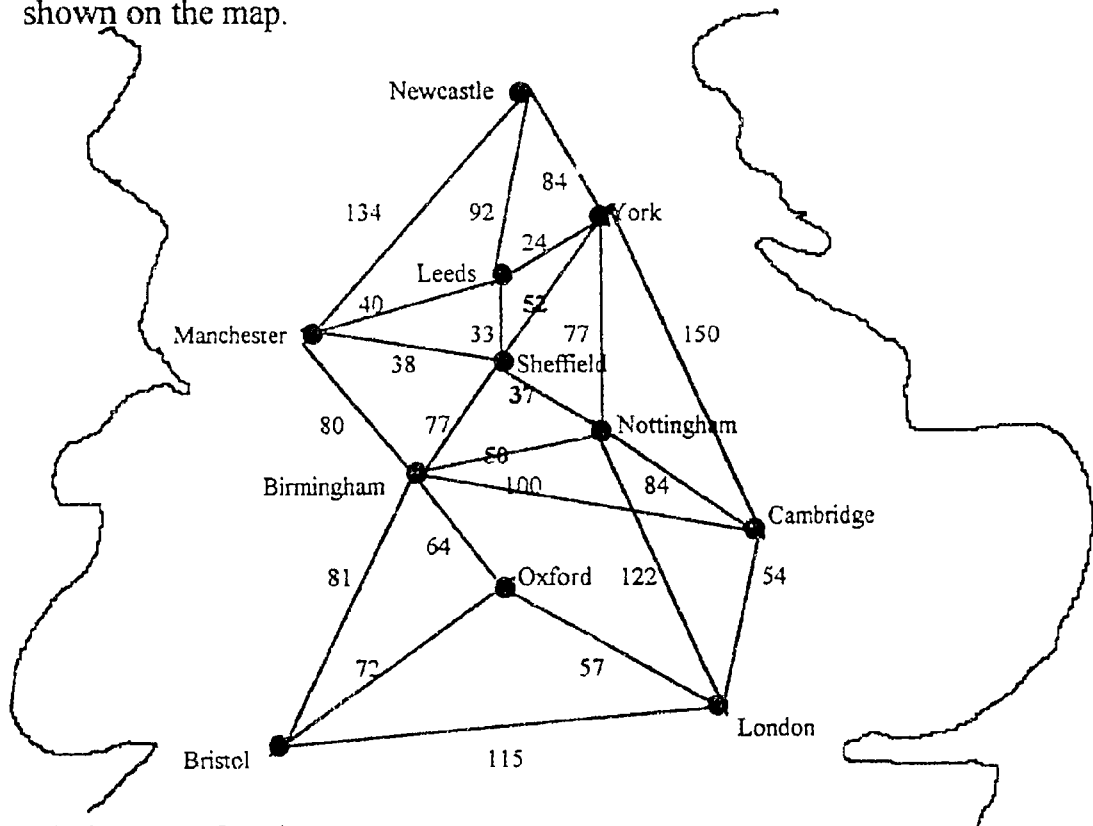

1. Find a route for him.
2. What is its total length?
3. Can you find a route of length less than 750 miles?
4. How long is the shortest route you can find?
5. If he no longer has to visit Sheffield, what is his shortest route?

Example - Junior 4, Mathematics Examination.

Answer all the questions and show all your working out.

1. Find the sum of 219, 4, 88 and 152.
2. Find the difference between 614 and 10004.
3. Find the product of 135 and 456.
4. What are the factors of 24
5. If 6 copies of the same book costs \$150, find the cost of each copy.
6. If one box of sweets cost 25c, find the cost of 12 boxes.
7. Add 4, 13, 16.9 and 0.04
8. Find the difference between 100 and 35.78
9. Write down the value of the underlined digits:
(a) 105637 (b) 2994376 (c) 3507065
10. A rectangular field measures 80m x 60m.
(a) What is the area?
(b) What is the perimeter?
11. (a) Draw a square and shade one quarter of it.
(b) Draw a rectangle and shade one third of it.
12. (a) $1\frac{1}{2} + 2\frac{3}{4}$ (b) $5\frac{1}{3} - 3\frac{5}{6}$
(c) $2\frac{1}{3} \times \frac{1}{2}$ (d) $3\frac{3}{4} \div \frac{3}{4}$
13. Complete these sequences:
(a) 44, 66, 88, ____, ____, ____
(b) 63, 76, 89, ____, ____, ____
(c) 16, ____, 24, ____, 32, 36, 40
14. What is the average of these sets of numbers?
(a) 7, 10, 8, 11
(b) 42, 38, 40, 73, 35
(c) 1.9, 0.9, 1.4, 1.0, 1.1

KAMP
 JUNIOR 4, MATHEMATICS EXAMINATION, ~~1977~~

Answer all the questions and show all your working out.

1. Find the sum of 219, 4, 88 and 152
2. Find the difference between 614 and 10004
3. Find the product of 135 and 456.
4. What are the factors of 24?
5. If 6 copies of the same book costs \$150, find the cost of each copy.
6. If one box of sweets costs 25c, find the cost of 12 boxes.
7. Add 4.13, 16.9 and 0.04
8. Find the difference between 100 and 35.78
9. Write down the value of the underlined digits:
 (a) 105637 (b) 2994376 (c) 3507065
10. A rectangular field measures 80m x 60m.
 (a) What is the area?
 (b) What is the perimeter?
11. (a) Draw a square and shade one quarter of it.
 (b) Draw a rectangle and shade one third of it.
12. (a) $1\frac{1}{2} + 2\frac{3}{4}$ (b) $5\frac{1}{2} - 3\frac{5}{6}$
 (c) $2\frac{1}{3} \times \frac{1}{2}$ (d) $3\frac{3}{4} \div \frac{7}{4}$ (/ = divide)
13. Complete these sequences:
 (a) 44, 66, 88, --, --, --
 (b) 63, 76, 89, ---, ---, ---
 (c) 16, --, 24, --, 32, 36, 40
14. What is the average of these sets of numbers?
 (a) 7, 10, 8, 11
 (b) 42, 38, 40, 73, 55
 (c) 1.9, 0.9, 1.1, 1.0, 1.1
15. The time for a 4 1/2 hr. game are followed
 question

15. If the time now is 4.15pm, answer the following questions:
- What will be the time half an hour later?
 - What will be the time 90 mins later?
 - What was the time one and a half hours ago?
 - What is the time now using a 24 hour clock?
16. A carton contains 1.5kg of flour. When full it contains 4kg. How much flour must be added to fill the carton?
17. A traffic survey was carried out in a village. These are the results:

Cars	Vans	Bicycles	Motor-bikes
25	45	15	20

Draw a graph to show the results.

18. A bottle contains 925ml of water. If 250ml is poured out, how much water is left in the bottle?

19. Copy this grid and mark the following points:

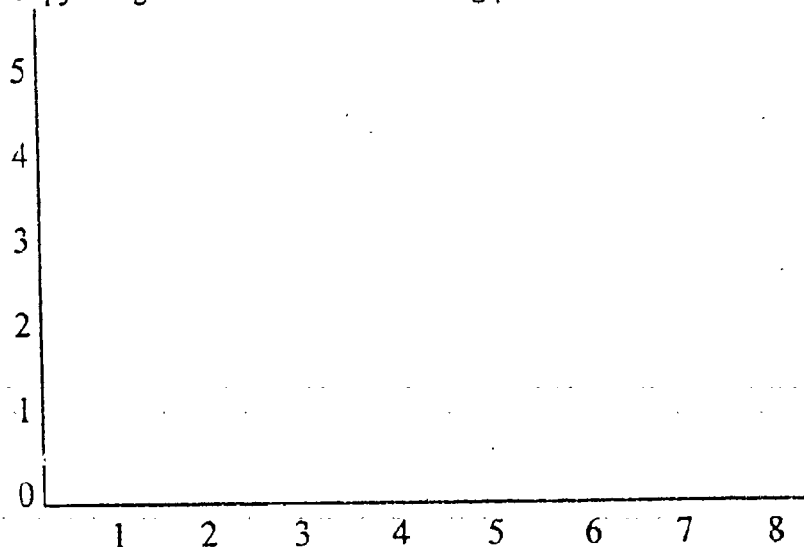

- Write the letter A on the point (3,2)
 - Write the letter B on the point (6,3)
 - Write the letter C on the point (4,5)
 - Write the letter D on the point (0,5)
20. Copy the following letters and mark on each one the lines of symmetry:
- A. C. E. X. Y
21. Draw a Venn diagram to show the following information:
Set A = {2,4,6,8} and Set B = {1,2,3,4,5}

22. (a) Draw a right angle.
(b) If two angles of a triangle are 56 degrees and 27 degrees, what is the size of the third angle?
23. Draw the following:
(a) two parallel lines (b) one vertical line
24. A car uses 1 litre of gas every 14km it travels. One litre of gas costs \$1.05. What is the cost of gasoline used in travelling 42 kilometres?

Other publications in this series include:

Maths and Science

1. A Practical Workbook for CXC Biology
2. Data Analysis Questions for Science Subjects. A Resource Booklet
3. Exercises and Activities in Basic Number Work
4. Fractions. Activities and Exercises for Teaching Fractions in Secondary Schools
5. Lower School Maths. Lesson Plans and Activities for Ages 7 -9 Years.
6. Maths and Science Booklet
7. Teaching Directed Numbers at Secondary School Level
8. Teachers' Resource Material for Integrated Science. Ideas for Teaching Integrated Science in Secondary Schools.
9. Upper School Maths Lesson Plans and Activities for Ages 9 -11 Years

Special Needs

10. An Introduction to Children with Special Needs for Teachers in Mainstream Education
11. The Alpha Centre: A Special School for Special Children. A Curriculum Checklist for Special Educational Needs.

English Language and Literacy

12. Language and Learning. A Practical Guide to Help with Planning your Early Childhood Programme.
13. Promoting Reading and Library Use in your School: A Resource Pack.
14. Strategies for Improving Language Across the Curriculum. Ideas and Activities for Every Classroom.
15. Your School Library. How it Works and How to Keep it Working.

Other

16. Beekeeping. A practical Guide to Beekeeping.
17. Caribbean Copy Art. A Resource Book for Teachers to Copy.
18. Methodology in Music Education.
19. Organising Workshops. A Practical Guide.

Many of these publications derive from projects or workshops funded through **VSO's Community Project Scheme** - an initiative also funded by grant from **British Development Division, Caribbean**.